

RTK GNSS QUADRIFILAR Helix Active Antenna

MODEL: GA-68D

Tapered size and ruggedness design, demand of vehicle locating and marine navigation GNSS antenna that will sustain harsh environment. The internal use of QUADRIFILAR Helix Antenna allows for a wider signal reception angle.



- Low noise figure
- Fully weather proof IPX7.
- Ultra-high Sensitivity
- Compact construction
- Excellent temperature stability
- Support GPS/GLONASS/BEIDOU/GALILEO and QZSS system

The antenna system **MA-680D** is the integration of the high performance GNSS QUADRIFILAR Helix antenna and a low noise amplifier into state-of-the-art low a very low profile/extremely compact/fully waterproof antenna signal enclosure. When connected to a GPS receiver with +3~16V DC antenna power it provide excellent signal amplification and out-band-rejection for that receiver.

Features:

GNSS antenna with double threaded bolts and through holes for cable routing with course & fine treaded pitch locking for wing-nut fastener and lock-nut to prevent vibrations and un-authorized removal.

Applications:

Geospatial Surveys / Single & Multiple frequencies RTK positioning / Vehicle Tracking / Security Surveillance / Precise Guidance / Machine Control / AVL

Specifications:

PHYSICAL CONDITION	
Constructions:	ASA-UV radome, detachable cable/connector for easy mount, rubber-O-ring between top radome and screw base for waterproof
Dimensions:	60mm(Dia.) x 90mm(H)
Weight:	170grams (w/o cable & connector).
Color:	Standard in ivory white,

Mounting:	Bulkhead mount with 0.8 inch threaded wing nut (standard accessory).
Cable & Connector	
RF cable:	SMA(M) +10 meter CFD200 +TNC(M)
Pulling strength:	6 Kg @ 5sec. molded plastic on connector end for strain relief.
Antenna Connector	SMA(F) or TNC(F)
Antenna Element	
SUPPORT Band:	GPS:L1/L2/L5 : GLONASS : L1/L2/L3 :BDS :B1/B2/B3 GALILEO:E1/E5/E6 & L-Band
Polarization:	R.H.C.P. (Right Handed Circular Polarization).
peak Gain:	≥ 2.5 dBi typical.
Gain @ 10° Elevation:	-1 dBi typical.
Axial Ratio@zenith:	≤ 2.0 dB
Azimuth coverage	360°
Output Impedance:	50 ohm
Low Noise Amplifier	
Center Frequency:	1164MHz~1283MHz & 1525MHz~1615MHz
Power Gain:	35db +/-3db
Group delay variation	≤ 2.0 db
Noise Figure:	1.5 tpy
Output VSWR	$\leq 2.0:1$
Supply Voltages:	3~16V DC.
Current Consumption:	≤ 30 mA (5V)
Output Impedance:	50 ohm
Overall Performance: (antenna element, LNA & coax cable)	
Center Frequency:	1164MHz~1283MHz & 1525MHz~1615MHz
Gain:	35db +/-3db
Noise Figure:	2.0 max.
Axial Ratio:	2 dB
Azimuth coverage	360°
VSWR:	2.0 max.
Output Impedance:	50ohm
Environmental	
Operating Temperature:	-40°C~ +85°C.

Storage Temperature:	-40°C~ +85°C.
Relative Humidity:	95% non-condensing.
Water Resistance:	100% waterproof.

* This specification is subject to change without prior notice

Data Updated: JUN.04, 2024

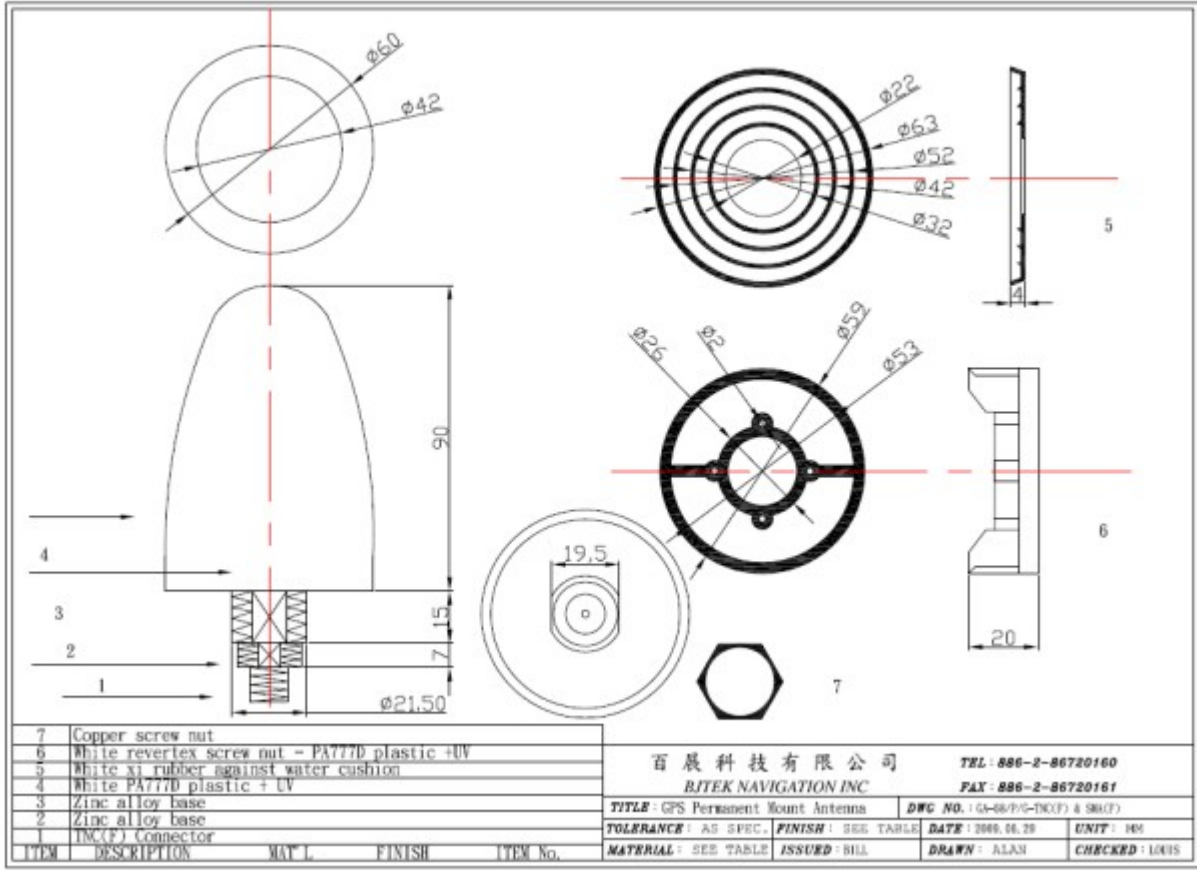

FB1 Base mounting

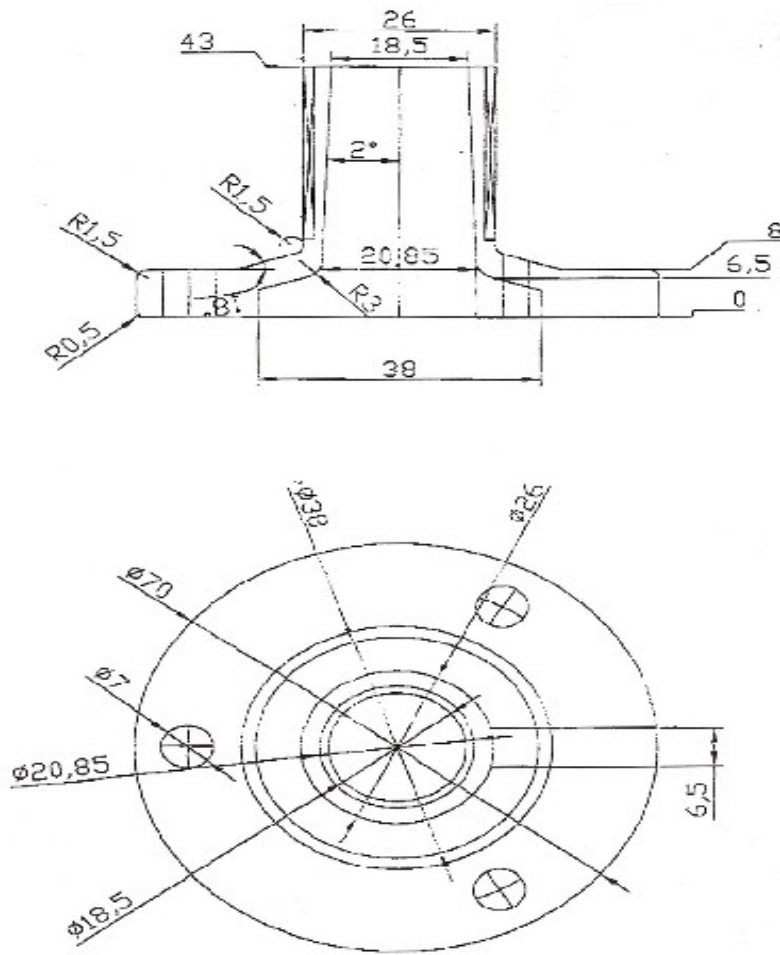

1. Antenna working frequency band

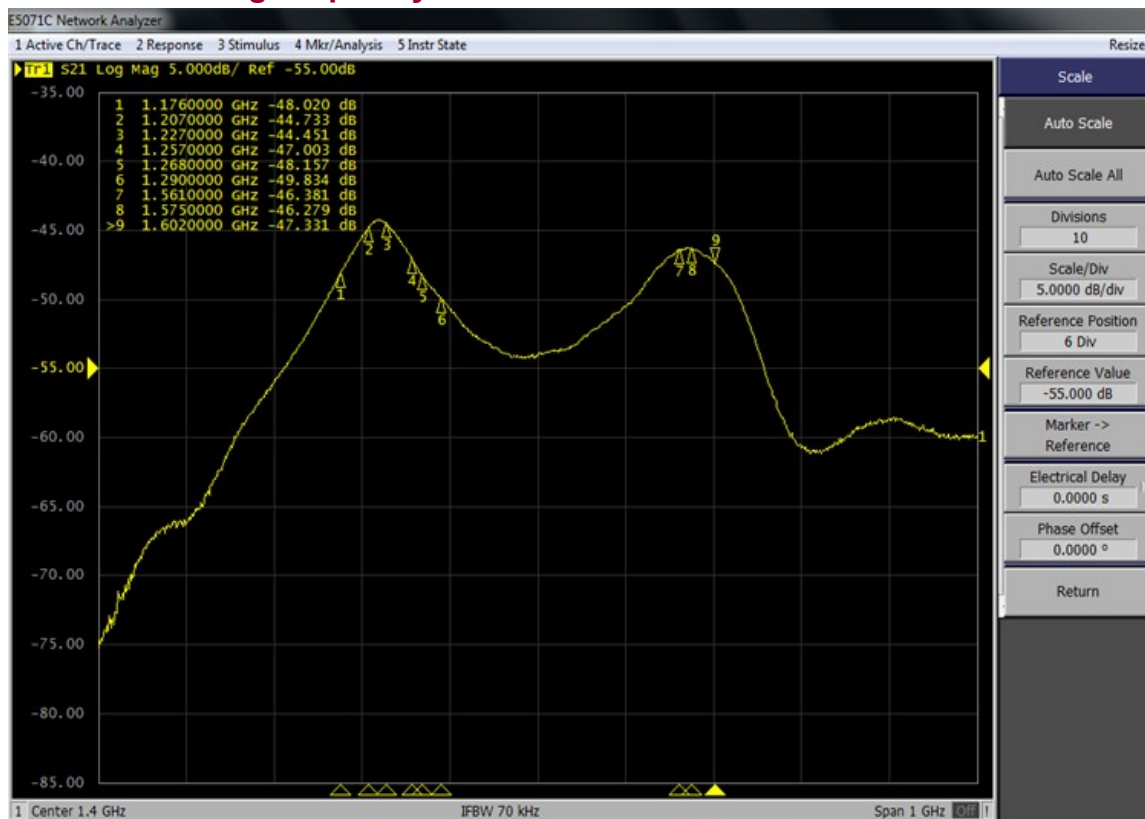

Passive antenna microwave anechoic chamber relative waveform diagram

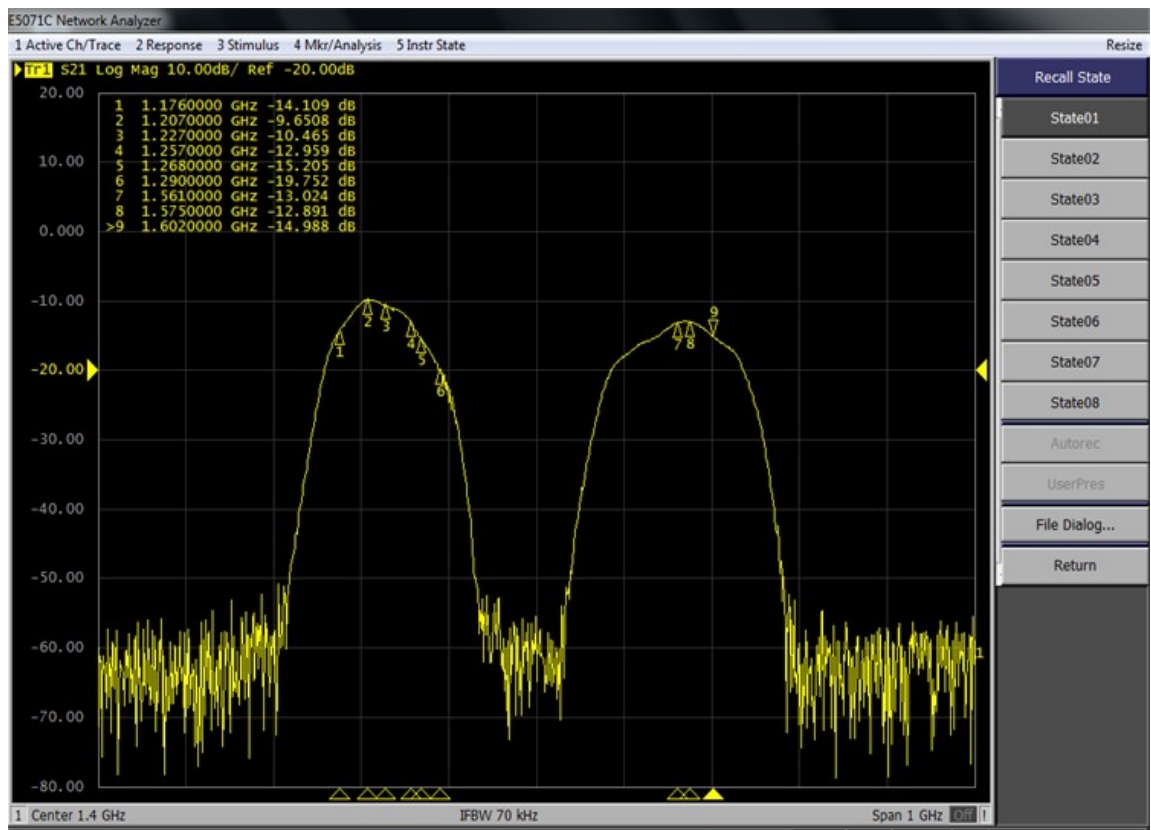

Active antenna microwave anechoic chamber relative waveform diagram

2. Antenna pattern and axial ratio

Typical direction diagram of L2 vertical plane

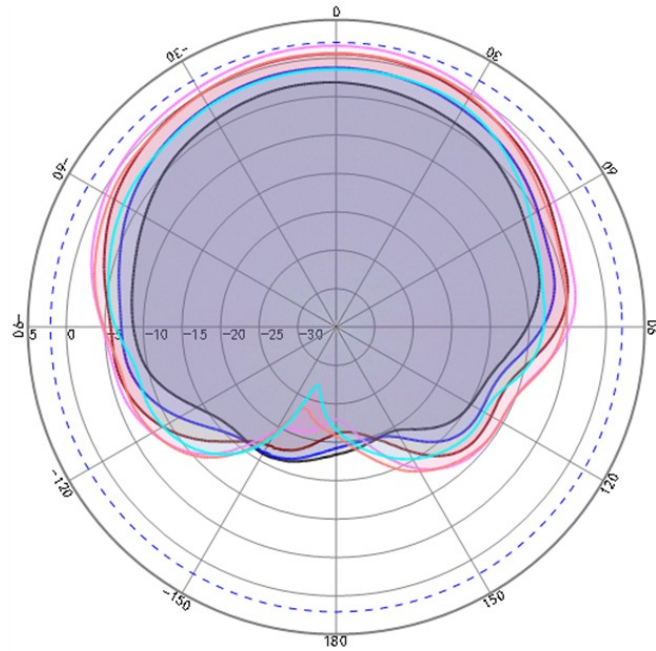

Freq(MHz)	Polarization	Peak gain(dBi)	HPBW(3dB)(deg)
1176	RHCP	-2.3	110
1192	RHCP	-0.3	115

1207	RHCP	1.5	117
1227	RHCP	2.8	117
1246	RHCP	1.6	119
1268	RHCP	0	120

Passive antenna vertical plane pattern@L2

Typical direction diagram of L1 vertical plane ($\phi=0$):

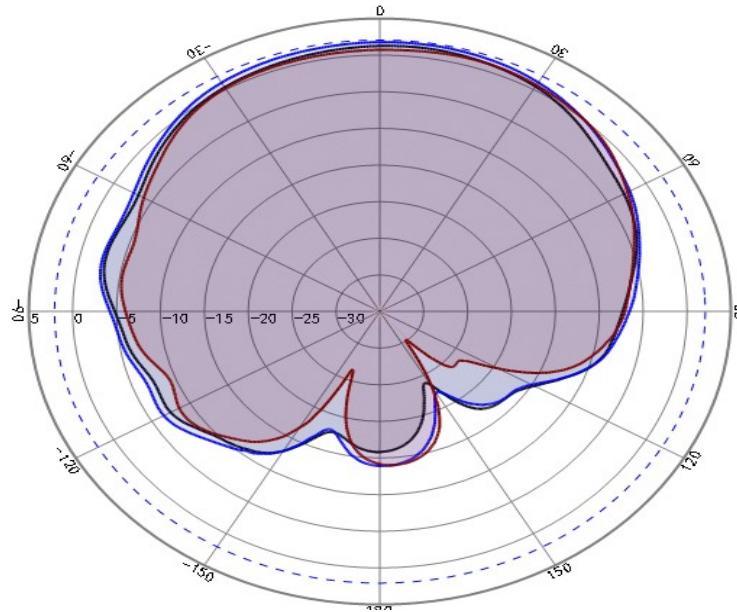

Freq(MHz)	Polarization	Peak gain(dBi)	HPBW(3dB)(deg)
1561	RHCP	2.3	96
1575	RHCP	2.7	100
1602	RHCP	2.0	101

Passive antenna L1 frequency band vertical plane pattern@L1

Typical direction diagram in the horizontal plane:

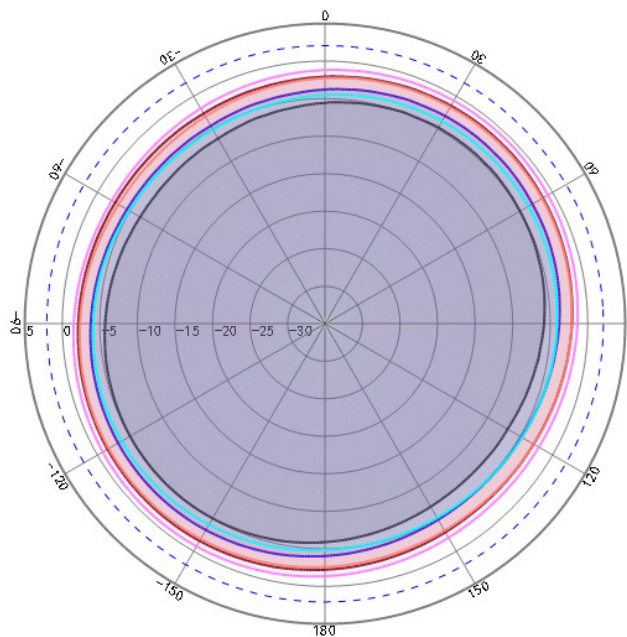

Freq(MHz)	Circularity(dB)
1176	1.2
1192	1.1

1207	0.9
1227	0.9
1246	1.0
1268	0.8

Passive gain out-of-roundness@L2

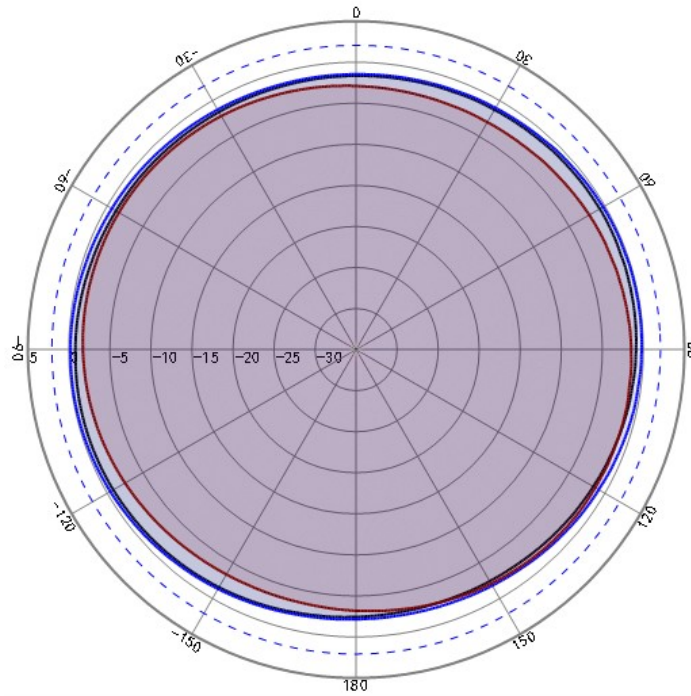

Freq(MHz)	Circularity(dB)
1561	0.9
1575	1.0
1602	1.2

Passive gain out-of-roundness@L1

Antenna axis ratio:

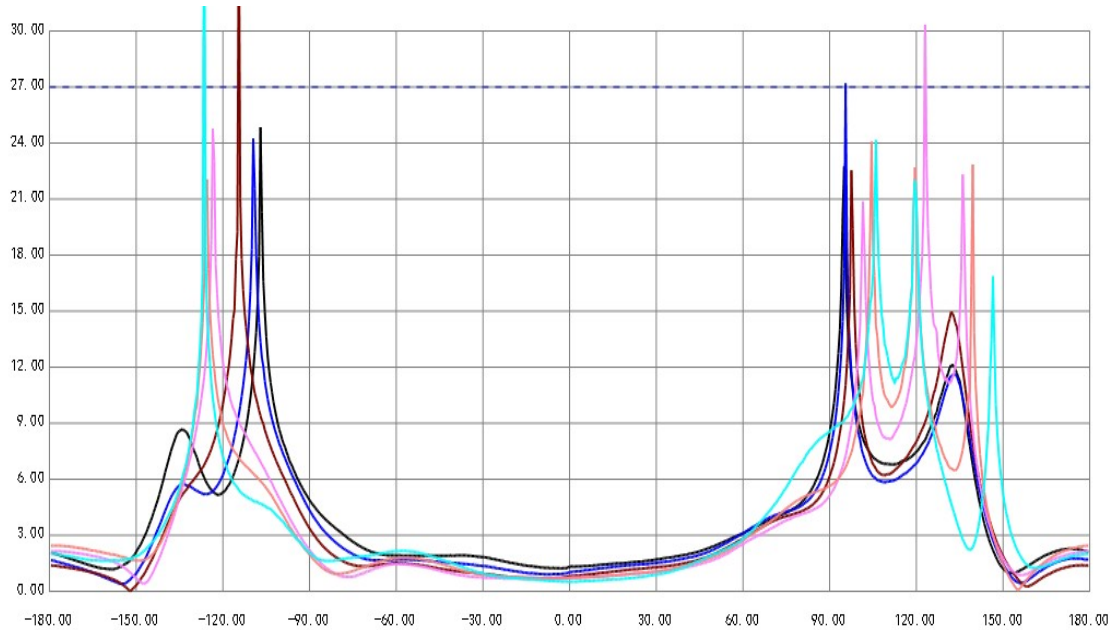

Freq(MHz)	@Zentth(dB)
1176	1.3

1192	1.0
1207	0.8
1227	0.7
1246	0.7
1268	0.6

Axle ratio@L2

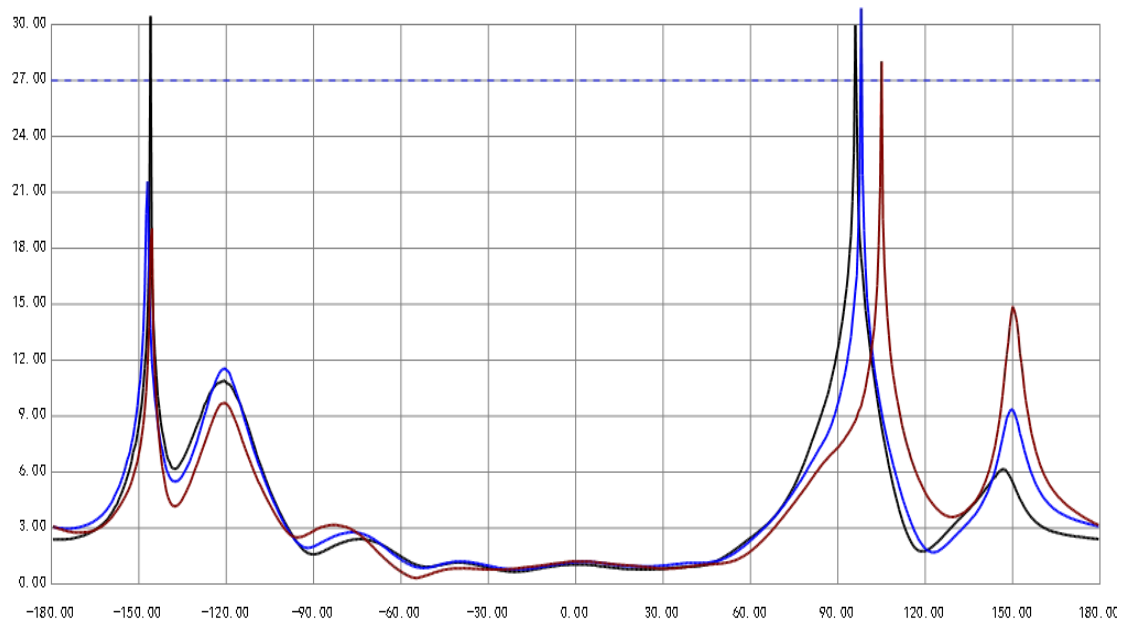

Freq(MHz)	@Zentth(dB)
1561	1.1
1575	1.2
1602	1.2

Axle ratio@L1

3. LNA gain and standing wave ratio

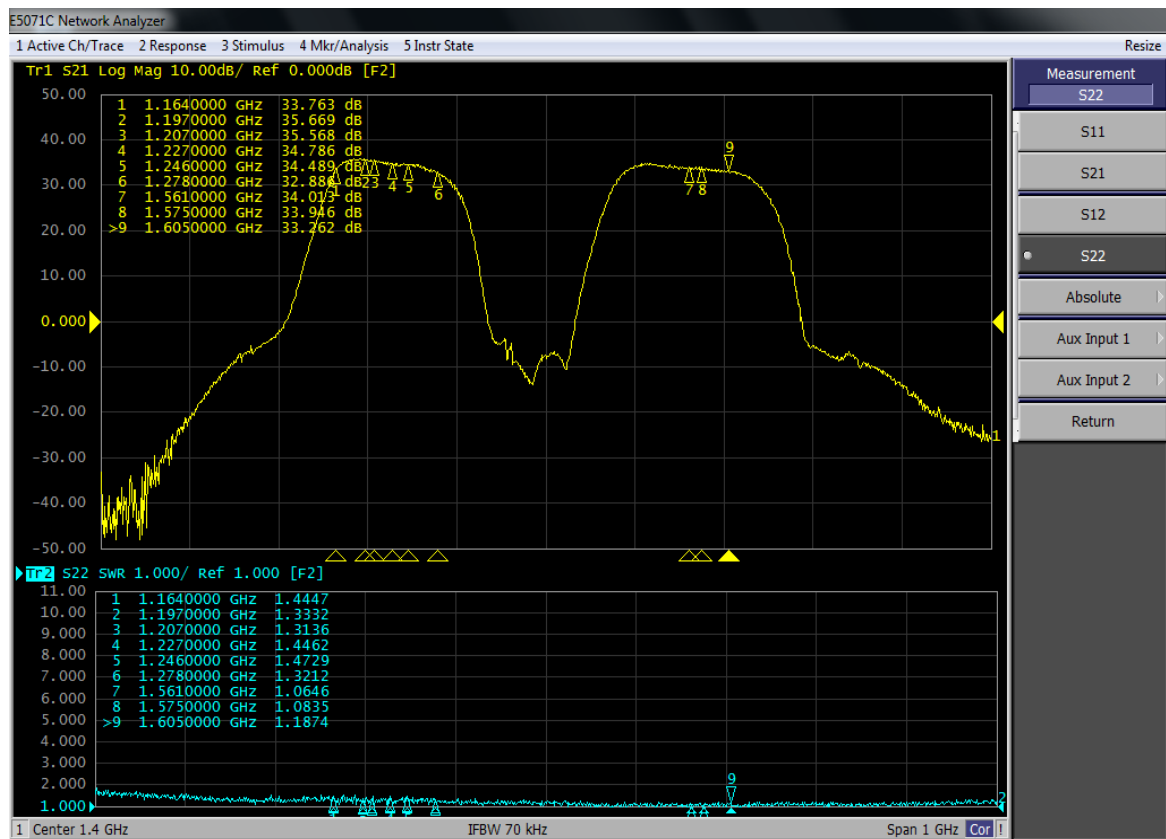

LNA gain and standing wave ratio

4. Working current



Working current is about 30mA

5. Test

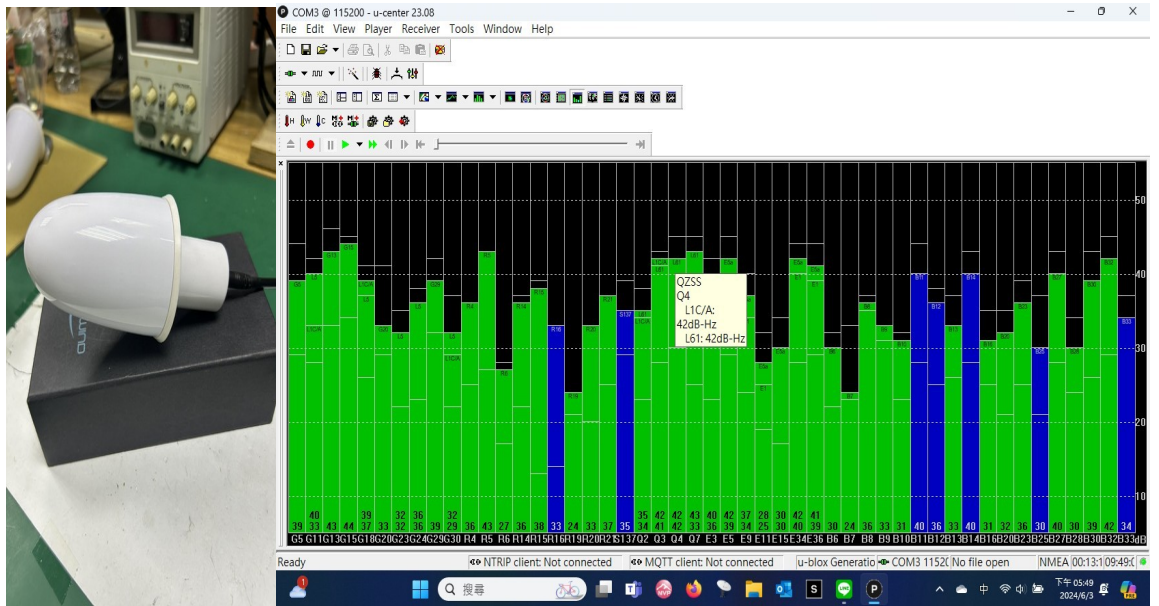
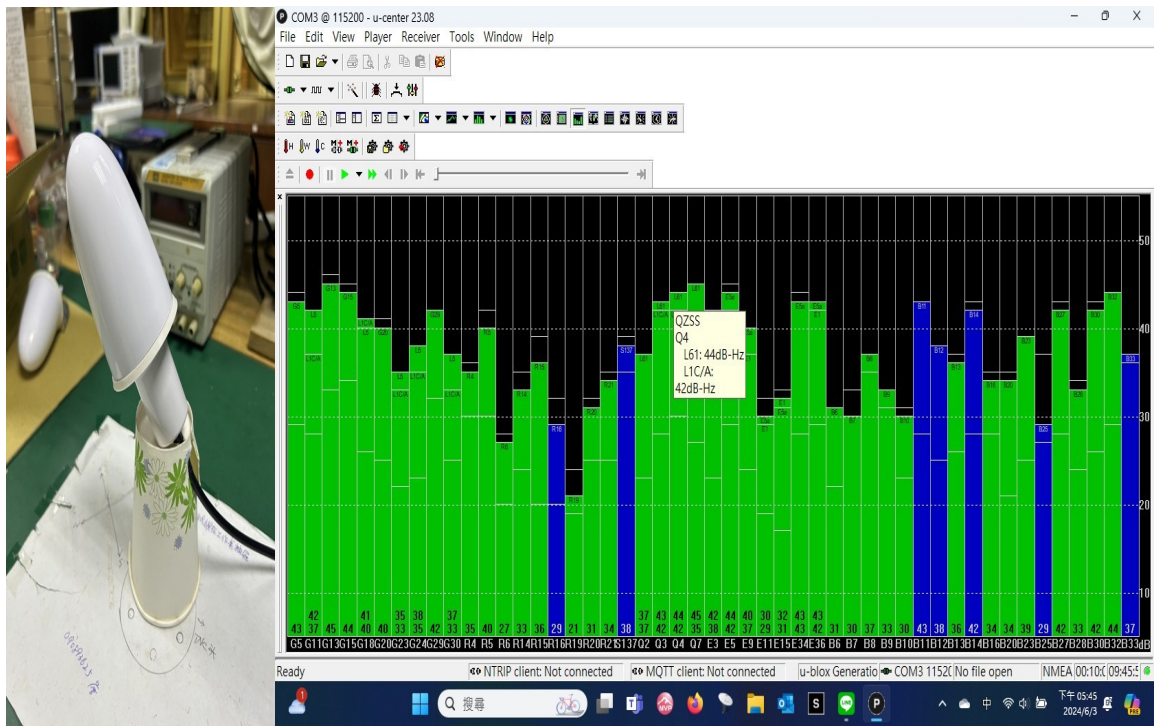

	• GPS	• GLONASS	• Galileo	• BeiDou	• SBAS	• QZSS	• NavIC	• L-Band
	Satellite	C/N0 [dB-Hz] Main, L1-C/A	C/N0 [dB-Hz] Main, L1-P(Y)	C/N0 [dB-Hz] Main, L2-P(Y)	C/N0 [dB-Hz] Main, L2C	C/N0 [dB-Hz] Main, L5		
Ch01	G11	44.00	33.75	33.75	45.50	42.75		
Ch02	G30							
Ch03	G15	40.00	24.50	24.50	30.00			
Ch04	G12	44.00	39.75	39.75	39.00			
Ch05	G19	34.75	14.00	14.00				
Ch08	G05	45.50	46.25	46.25	45.25			
Ch09	G13	43.25	27.25	27.25				
Ch10	G06							
Ch11	G20	45.00	33.50	33.50				
Ch12	G29							
Ch13	G25							

	• GPS	• GLONASS	• Galileo	• BeiDou	• SBAS	• QZSS	• NavIC	• L-Band
	Satellite	FN	C/N0 [dB-Hz] Main, L1-C/A	C/N0 [dB-Hz] Main, L2-P	C/N0 [dB-Hz] Main, L2-C/A	C/N0 [dB-Hz] Main, L3		
Ch29	R07	5	48.25	44.25	43.75			
Ch30	R22	-3	30.00	34.50	34.75			
Ch31	R20	2						
Ch32	R08	6	49.00	41.25	40.50			
Ch34	R21	4	51.50	48.50	47.75	46.75		

	• GPS	• GLONASS	• Galileo	• BeiDou	• SBAS	• QZSS	• NavIC	• L-Band	
	Satellite	C/N0 [dB-Hz] Main, L1BC	C/N0 [dB-Hz] Main, E6BC	C/N0 [dB-Hz] Main, E5a	C/N0 [dB-Hz] Main, E5b	C/N0 [dB-Hz] Main, E5			Galileo Services
Ch07	E21	36.25	37.25	35.25	31.50	36.50			OS/SOL/CS
Ch14	E07	44.50	41.75	44.25	47.00	48.75			OS/SOL/CS
Ch15	E33	30.25	32.75						OS/SOL/CS
Ch16	E08								
Ch17	E26	38.25	42.00		36.25				OS/SOL/CS
Ch18	E13	37.00	37.00		35.75				OS/SOL/CS
Ch20	E15								

	• GPS	• GLONASS	• Galileo	• BeiDou	• SBAS	• QZSS	• NavIC	• L-Band	
	Satellite	C/N0 [dB-Hz] Main, B1I	C/N0 [dB-Hz] Main, B2I	C/N0 [dB-Hz] Main, B3I	C/N0 [dB-Hz] Main, B1C	C/N0 [dB-Hz] Main, B2a	C/N0 [dB-Hz] Main, B2b		
Ch35	C50								
Ch36	C22								
Ch38	C05								
Ch39	C14	46.00	44.50	43.50					
Ch40	C04								
Ch41	C11	36.75	41.25	37.00					
Ch42	C60	37.75		45.75					41.00
Ch43	C02	36.50	41.75	43.25					
Ch44	C08	38.50	40.00	39.50					
Ch45	C13	44.50	43.25	42.75					
Ch46	C40	46.25		46.25	44.50	41.00	44.00		
Ch47	C38	43.00		42.00	42.25	38.25	43.25		
Ch48	C07	40.75	44.00	42.75					
Ch49	C01	38.00	37.50	36.25					
Ch50	C10	40.00	40.00	42.75					

	GPS	GLONASS	Galileo	BeiDou	SBAS	QZSS	NavIC	L-Band
Channel	Satellite	Satellite Name	C/N0 [dB-Hz] Main, L1	C/N0 [dB-Hz] Main, L5				
Ch21	S137	MTSAT-2, MSAS	42.25					
Ch22	S127	GSAT-8, GAGAN						
Ch23	S144	G1, BDSBAS	38.75	39.25				
Ch24	S130	G6, BDSBAS	44.00	39.75				
Ch25	S128	GSAT-10, GAGAN	40.50	40.50				
Ch26	S134	INMARSAT 5F3, KAAS	44.75	39.00				
Ch27	S132	GSAT-15, GAGAN	43.00	37.00				
Ch28	S143	G3, BDSBAS	46.25	42.50				

	GPS	GLONASS	Galileo	BeiDou	SBAS	QZSS	NavIC	L-Band
Channel	Satellite	C/N0 [dB-Hz] Main, L1-C/A	C/N0 [dB-Hz] Main, L2C	C/N0 [dB-Hz] Main, L5	C/N0 [dB-Hz] Main, L6			
Ch17	J03	45.75	46.75	43.50	42.00			
Ch50	J07	40.00	45.75	42.75				

	GPS	GLONASS	Galileo	BeiDou	SBAS	QZSS	NavIC	L-Band
Satellite	C/N0 [dB-Hz] Main, L5							