

# X-Band Passive Antenna

**MODEL: GA-7500**



Antenna Size : 60mm(Dia) × 18.5mm(H)

Specifications	
<b>Antenna Element</b>	
Center Frequency	7200-7800Mhz
Polarization	R.H.C.P. (Right Handed Circular Polarization)
Output VSWR	2.0:1
Output Impedance	50 ohm
<b>Environmental Conditions</b>	
Operating Temperature	-40°C to +85°C
Storage Temperature	-40°C to +85°C
Relative Humidity	40% to 95% non-condensing
Water Resistance	100% waterproof
<b>Physical Constructions</b>	
Dimensions	Antenna : 60mm(Dia.) × 18.5mm(H)
Weight	65 grams (without cable)
Mounting	Bulkhead mount with 0.8 inch threaded wing nut (standard accessory).
<b>Cable &amp; Connector</b>	
RF Cable	Without cable
Connector available	SMA(F)

\* This specification is subject to change without prior notice

Data Updated: JAN 25, 2022

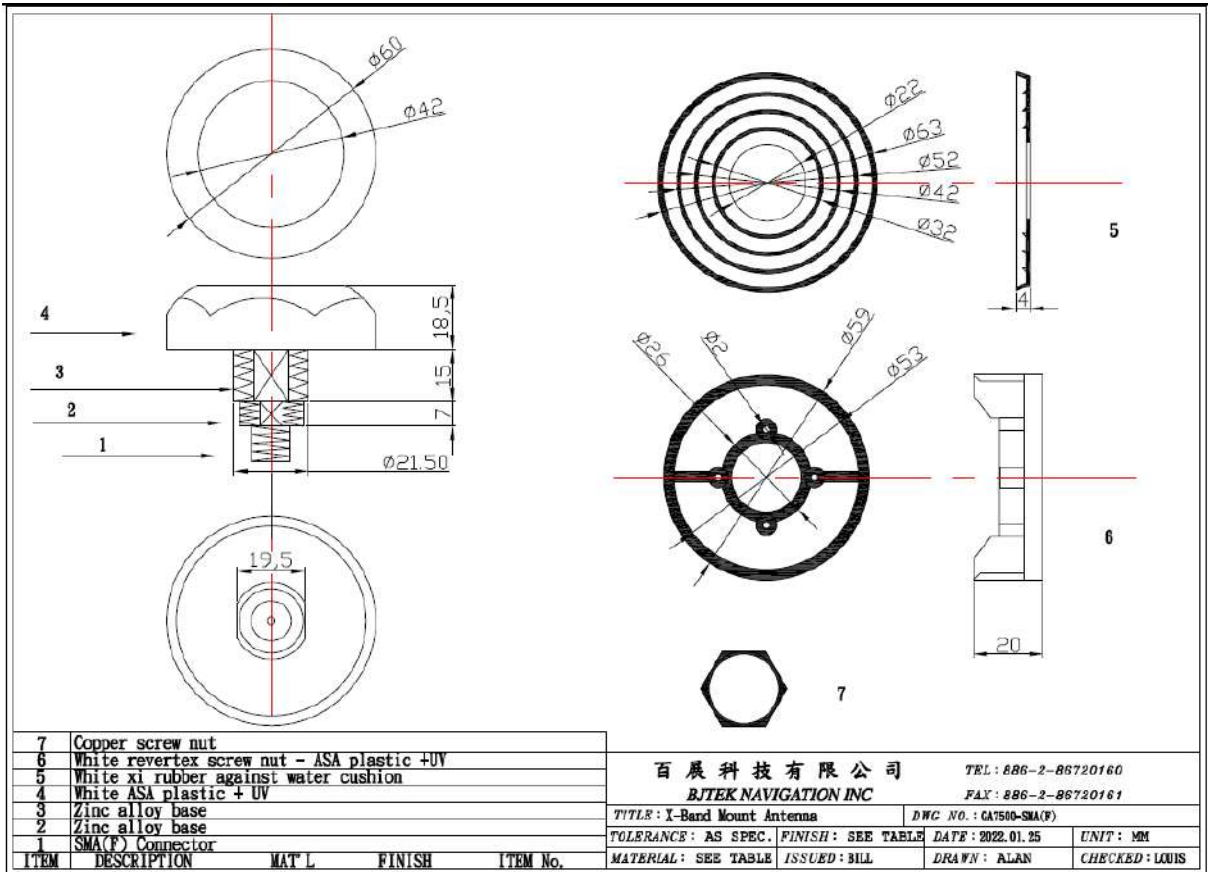

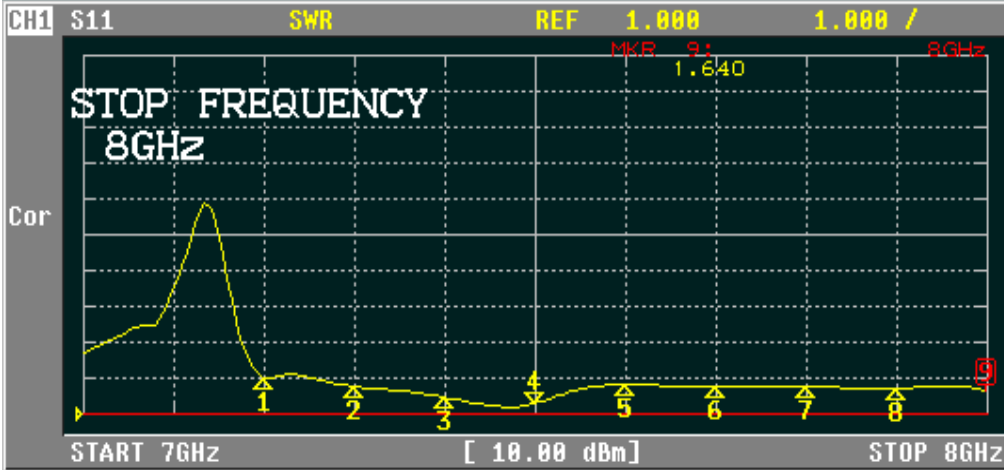

CH1 MARKER LIST

1:	7.200 000GHz	2.029
2:	7.300 000GHz	1.758
3:	7.400 000GHz	1.462
4:	7.500 000GHz	1.300
5:	7.600 000GHz	1.822
6:	7.700 000GHz	1.751
7:	7.800 000GHz	1.776
8:	7.900 000GHz	1.719
9:	8.000 000GHz	1.640
10:		

CAL MENU

1 PORT FULL CAL

2 PORT CAL MENU

AUTO CAL

CLEAR CAL DATA

CAL KIT

DON'T

Return

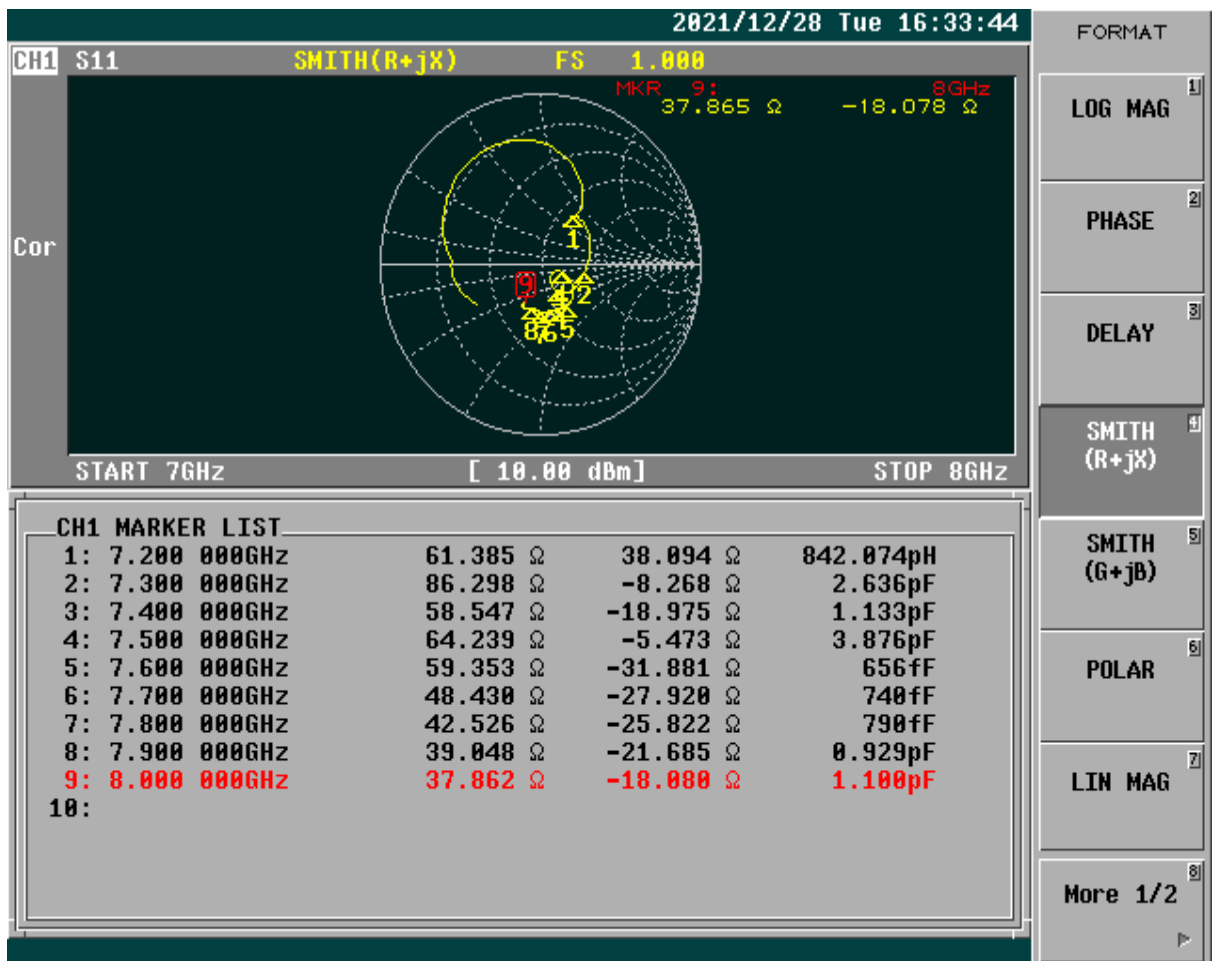
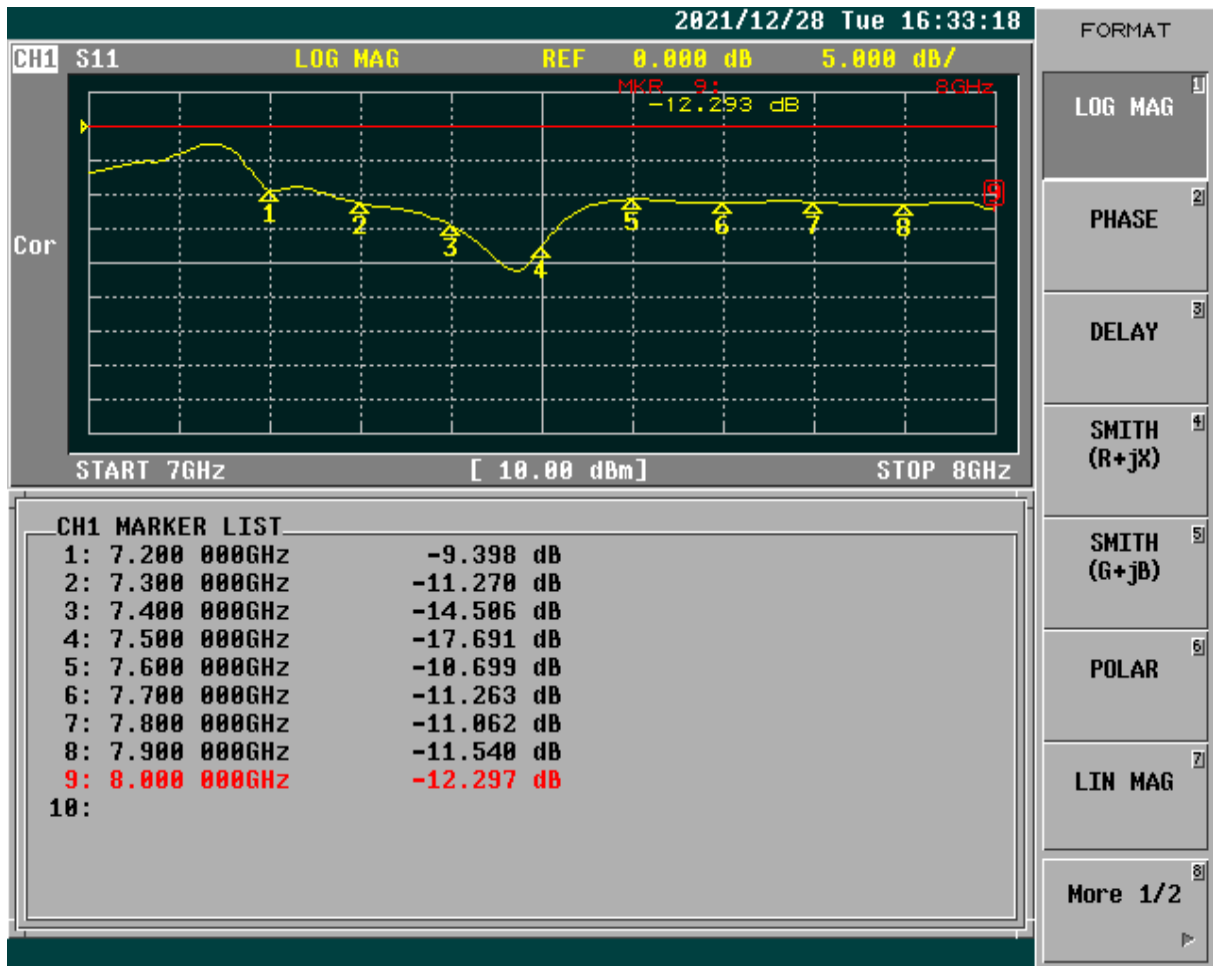

Frequency (MHz)	7200	7300	7400	7500	7600	7700	7800
Peak Gain (dBi)	3.73	5.86	6.85	6.65	4.32	3.89	3.69
Efficiency (%)	39.67	50.09	66.20	61.53	59.20	44.81	34.25

### 7200MHz

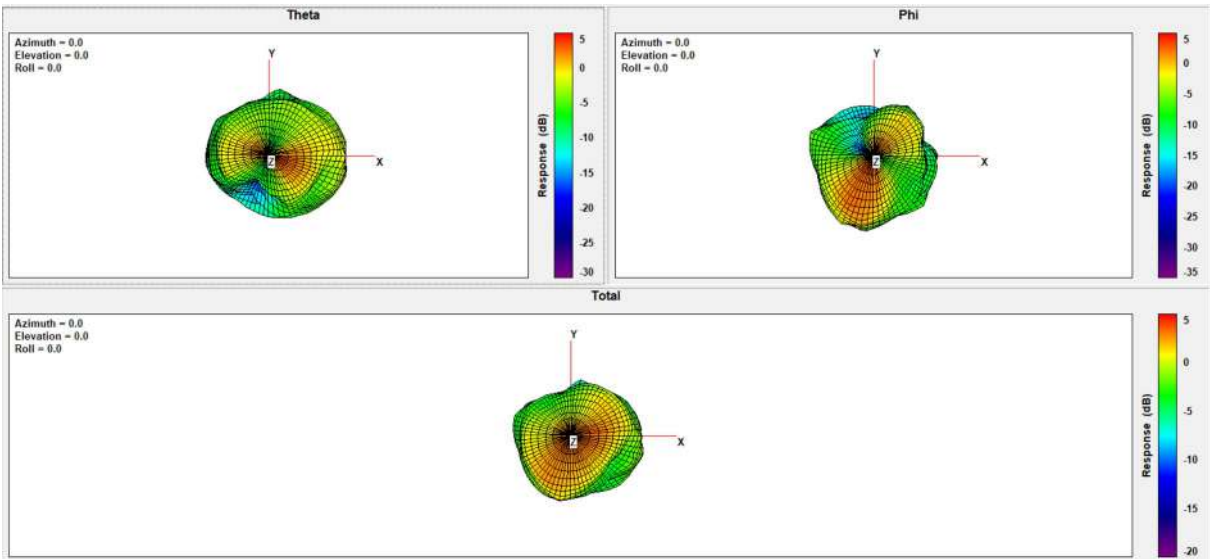

### 7300MHz

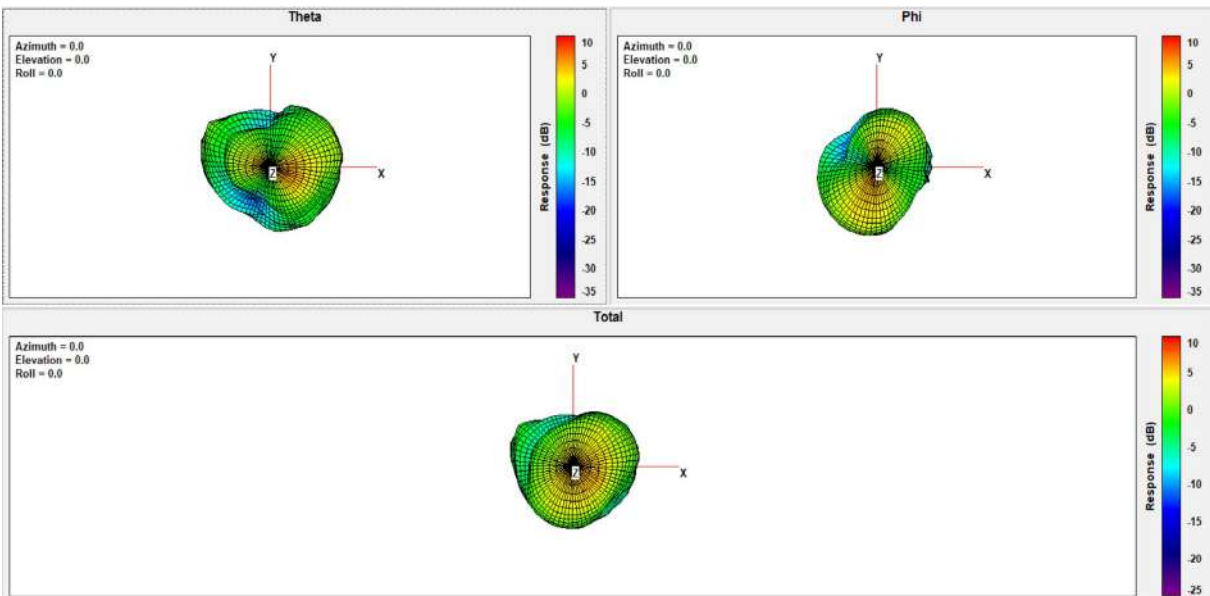

### 7400MHz

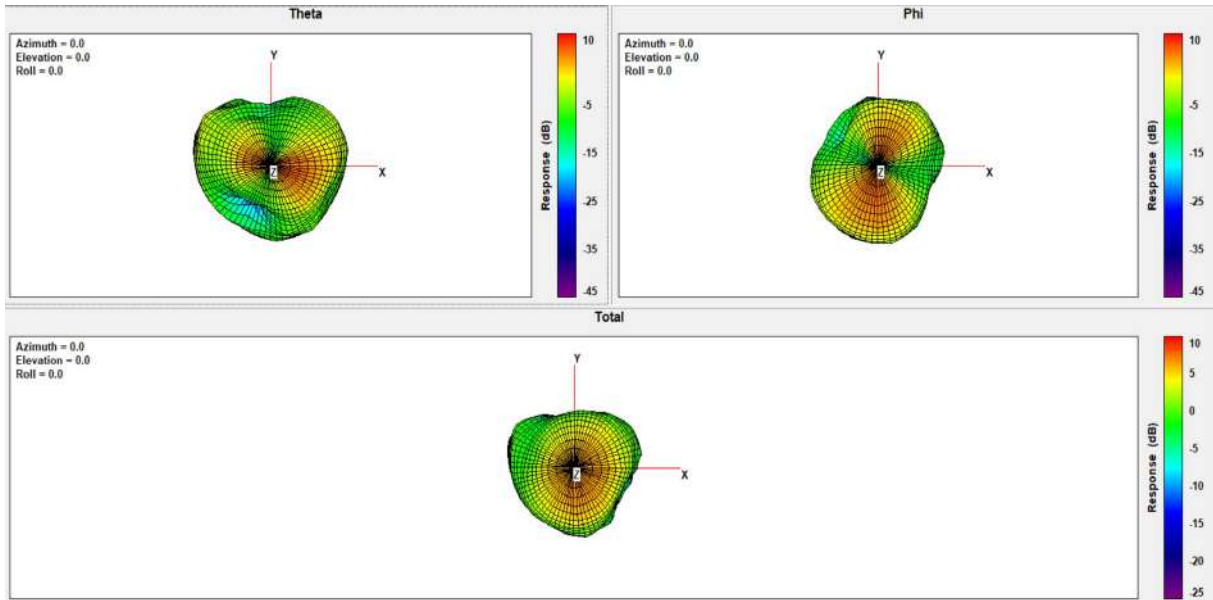

### 7500Mhz

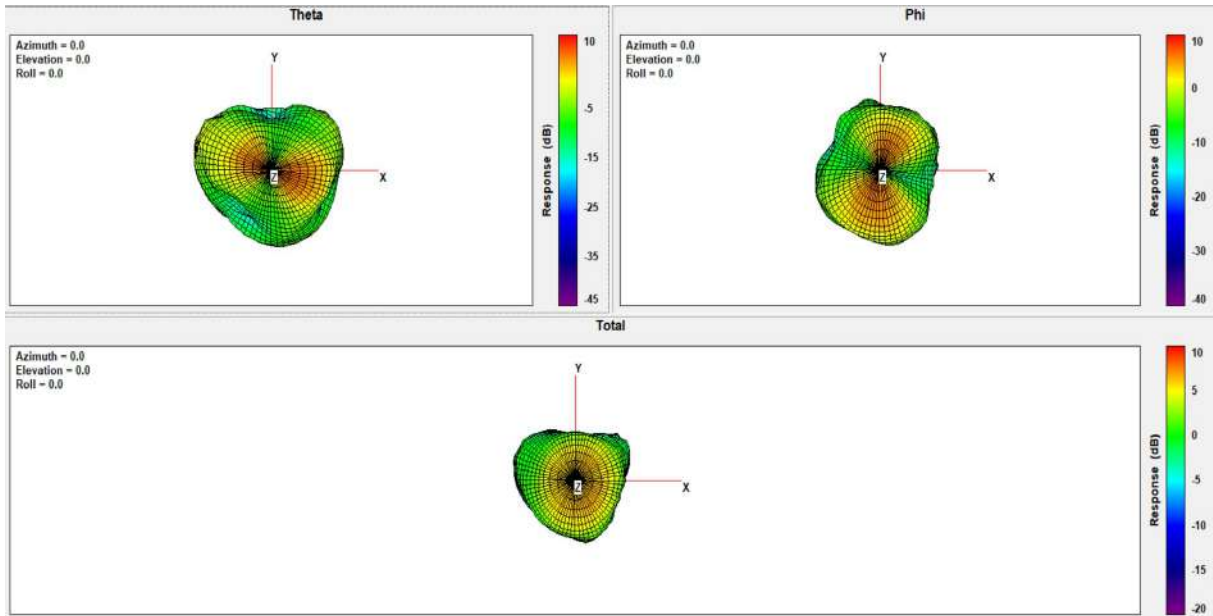

### 7600 Mhz

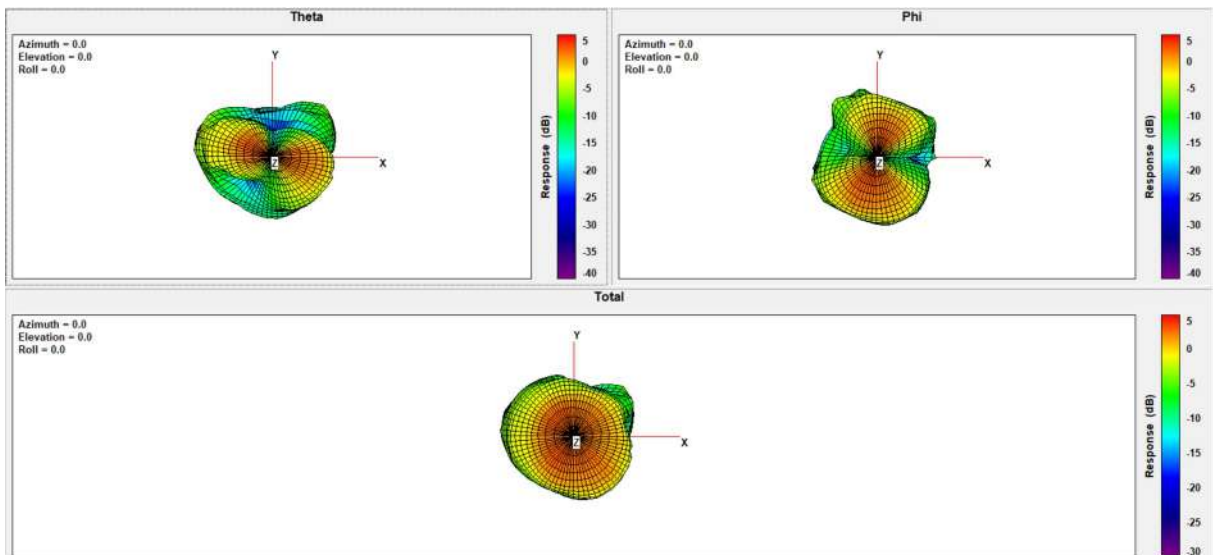

### 7700 Mhz



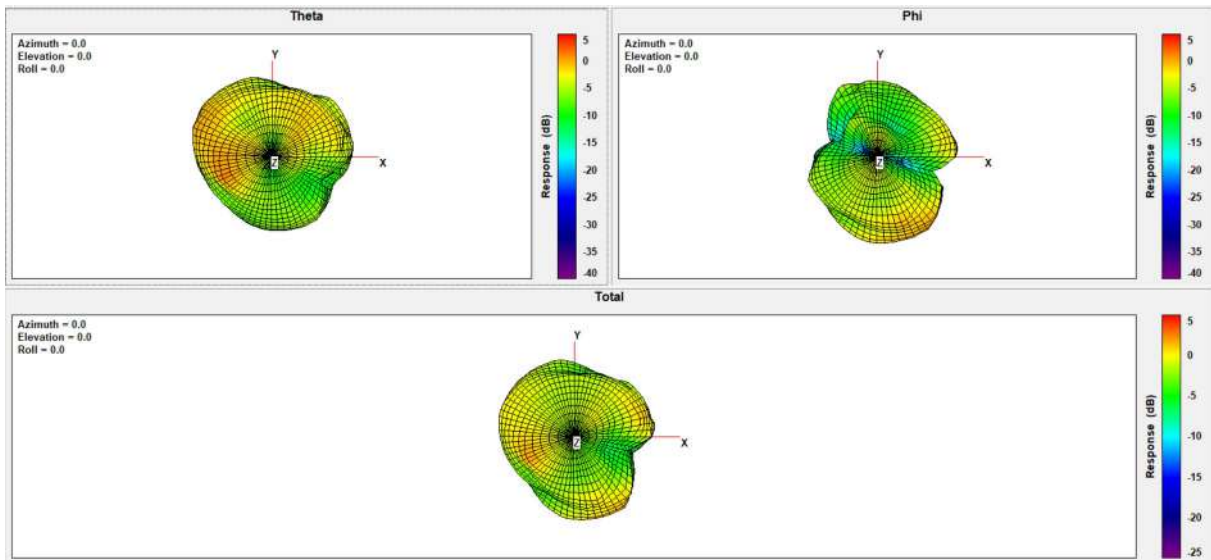

7800Mhz

