

Outdoor/Indoor 2.4 / 5.8G Antenna

MODEL: WA-680L



Specifications:

| PHYSICAL CONDITION | |
|-------------------------|--|
| Constructions: | ASA-UV + Zinc alloy-Ni |
| Dimensions: | 60mm(Dia.) x 140mm(H) |
| Weight: | 280grams (w/o cable & connector). |
| Color: | Standard in ivory white, other colours available upon request. |
| Mounting: | Bulkhead mount with 0.8 inch threaded wing nut (standard accessory). |
| Base mounting | FB9 SUS316 L- mounting |
| Cable & Connector | |
| RF cable: | SMA(M) +5meter +SMA(M) (standard) other length (optional) |
| Pulling strength: | 6 Kg @ 5sec. molded plastic on connector end for strain relief. |
| Connector | SMA(F) |
| Antenna Element | |
| Center Frequency: | 2400~2500 / 5100~5850 MHz |
| Polarization: | Linear |
| Absolute Gain @ Zenith: | 1~4 dBi without cable |
| Output VSWR: | 3.0 max |
| Output Impedance: | 50 ohm |
| Environmental | |
| Operating Temperature: | -40°C~ +85°C. |
| Storage Temperature: | -40°C~ +85°C. |
| Relative Humidity: | 95% non-condensing. |
| Water Resistance: | 100% waterproof. IPX7 |

* This specification is subject to change without prior notice

Data Updated: jun.09, 2023

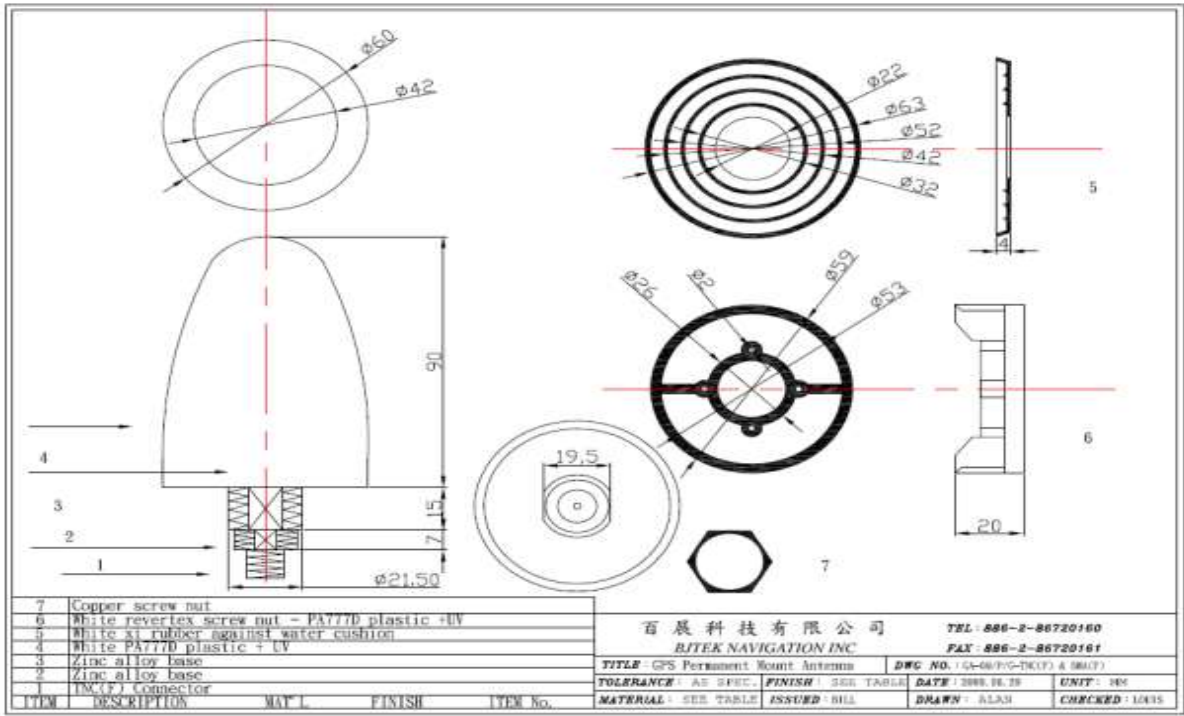

SUS316 Antenna L- mounting

MODEL: FB-9

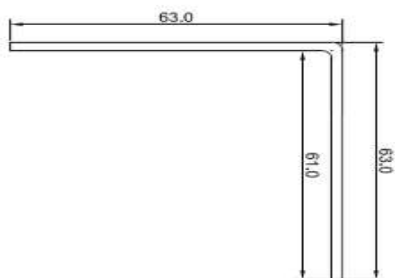
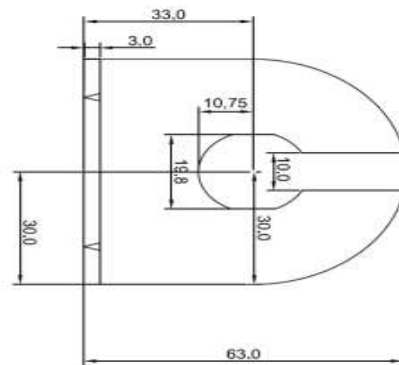
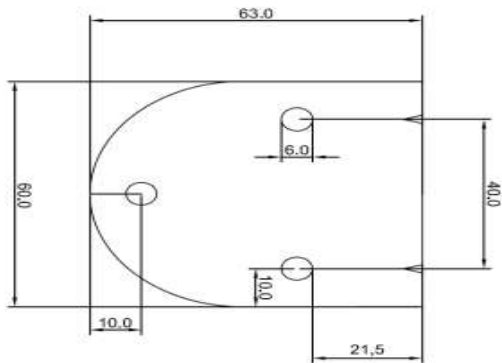

SUS316 T20

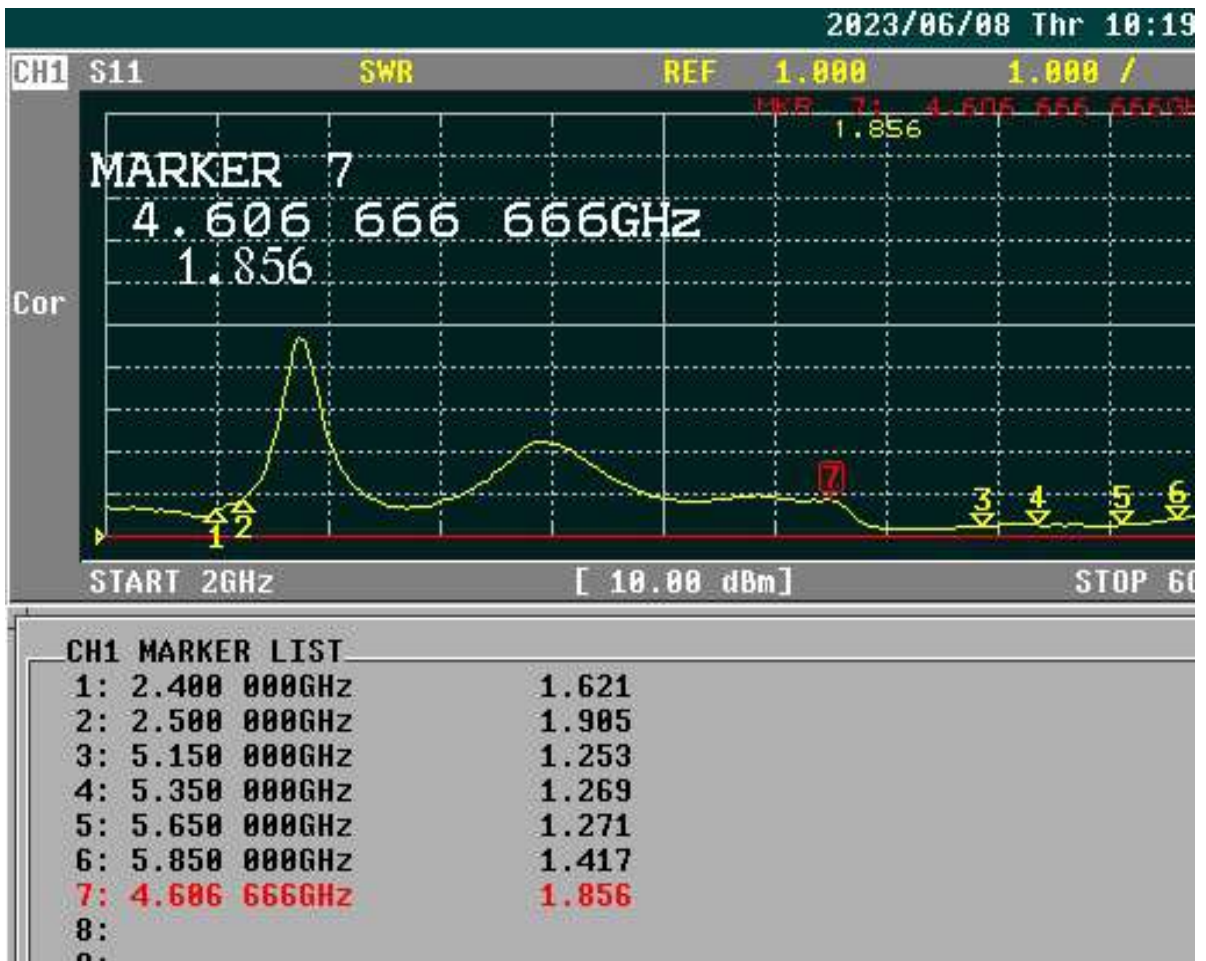
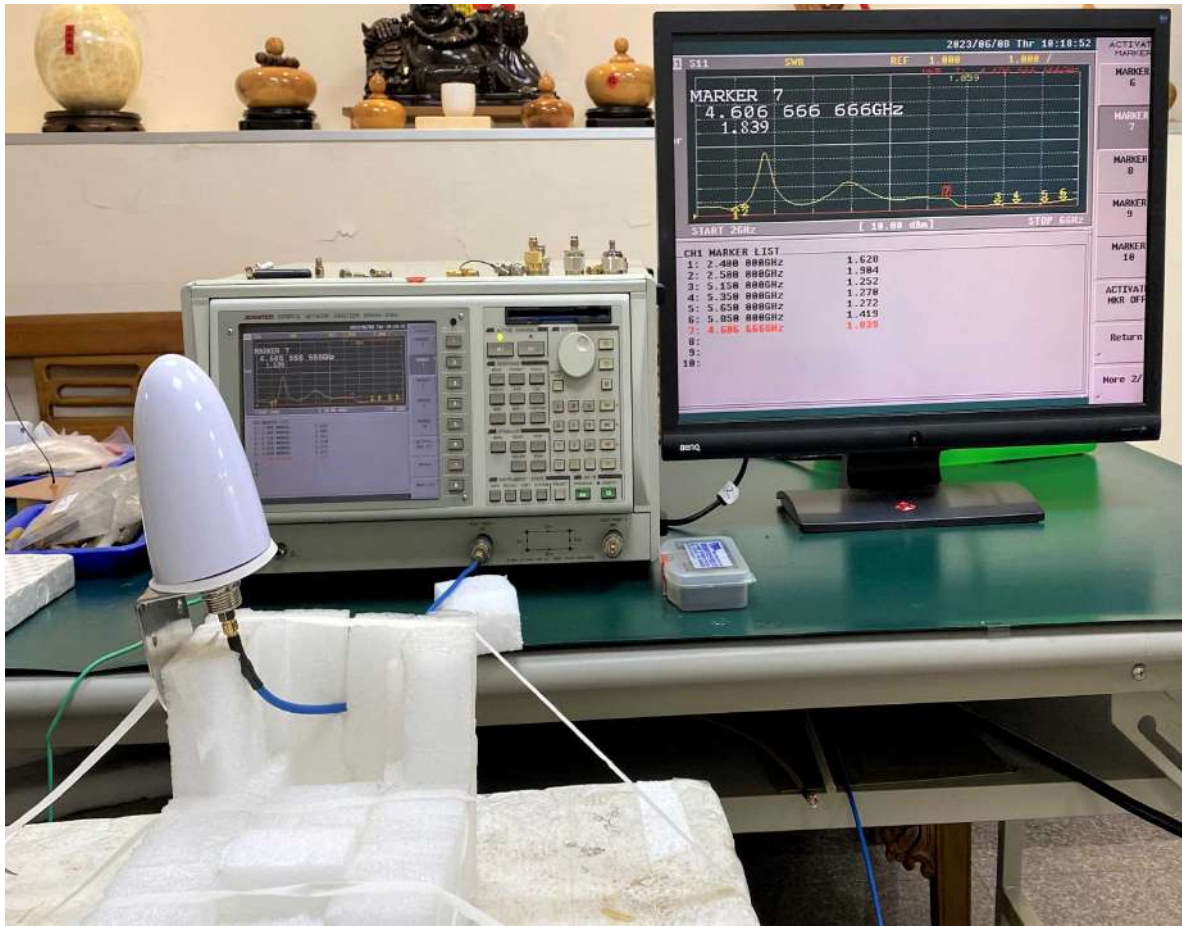



CH1 MARKER LIST

| | | |
|----|--------------|------------|
| 1: | 2.400 000GHz | -12.239 dB |
| 2: | 2.500 000GHz | -9.737 dB |
| 3: | 5.150 000GHz | -18.828 dB |
| 4: | 5.350 000GHz | -18.247 dB |
| 5: | 5.650 000GHz | -18.870 dB |
| 6: | 5.850 000GHz | -15.787 dB |
| 7: | 4.606 666GHz | -10.367 dB |
| 8: | | |
| 9: | | |



CH1 MARKER LIST

| | | | | |
|----|--------------|----------|-----------|-----------|
| 1: | 2.400 000GHz | 44.661 Ω | 23.391 Ω | 1.551nH |
| 2: | 2.500 000GHz | 49.753 Ω | 33.490 Ω | 2.132nH |
| 3: | 5.150 000GHz | 40.376 Ω | -4.853 Ω | 6.367pF |
| 4: | 5.350 000GHz | 38.916 Ω | 2.576 Ω | 76.642pH |
| 5: | 5.650 000GHz | 43.637 Ω | 9.191 Ω | 258.901pH |
| 6: | 5.850 000GHz | 45.600 Ω | 14.922 Ω | 405.971pH |
| 7: | 4.606 666GHz | 38.429 Ω | -25.107 Ω | 1.376pF |
| 8: | | | | |
| 9: | | | | |

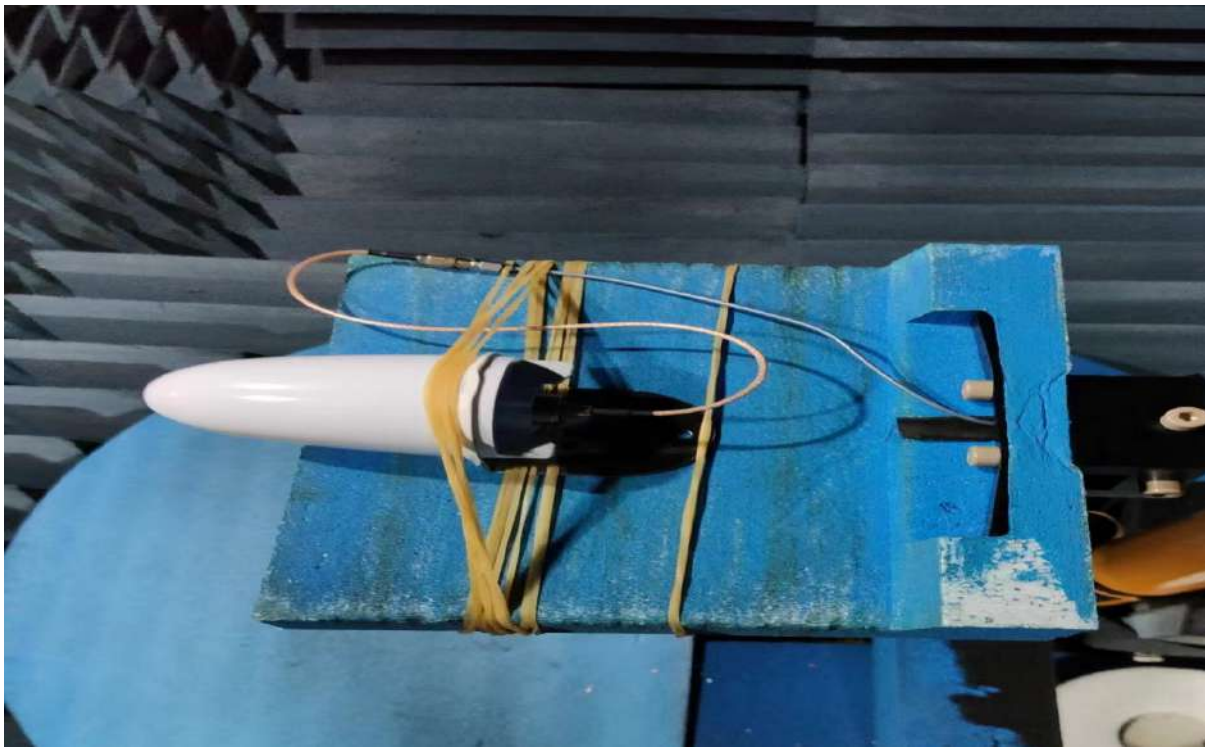

3D Total

| Frequency (MHz) | Upper Hem. PRP (dBm) | Lower HEM. PRP (dBm) | Efficiency (dB) | Efficiency (%) | Gain (dBi) | Tot. Rad.Pwr. (dBm) |
|-----------------|----------------------|----------------------|-----------------|----------------|------------|---------------------|
| 1800 MHz | -5.64 | -5.79 | -2.70 | 53.66 | 2.22 | -2.70 |
| 1900 MHz | -5.50 | -5.89 | -2.68 | 53.93 | 2.01 | -2.68 |
| 2000 MHz | -4.79 | -5.37 | -2.06 | 62.26 | 2.49 | -2.06 |
| 2100 MHz | -4.96 | -6.05 | -2.46 | 56.75 | 2.36 | -2.46 |
| 2200 MHz | -5.37 | -6.99 | -3.09 | 49.07 | 1.71 | -3.09 |
| 2250 MHz | -4.35 | -6.33 | -2.22 | 59.98 | 2.84 | -2.22 |
| 2300 MHz | -3.78 | -5.83 | -1.68 | 67.98 | 4.03 | -1.68 |
| 2350 MHz | -4.03 | -6.36 | -2.03 | 62.66 | 4.14 | -2.03 |
| 2400 MHz | -5.26 | -7.84 | -3.35 | 46.21 | 1.77 | -3.35 |
| 2450 MHz | -4.49 | -7.21 | -2.63 | 54.60 | 2.29 | -2.63 |
| 2500 MHz | -5.96 | -8.87 | -4.16 | 38.35 | 1.28 | -4.16 |
| 4600 MHz | -2.78 | -4.40 | -0.50 | 89.03 | 5.95 | -0.50 |
| 4700 MHz | -3.67 | -3.47 | -0.56 | 87.84 | 6.74 | -0.56 |
| 4800 MHz | -5.64 | -6.98 | -3.25 | 47.34 | 5.97 | -3.25 |
| 4900 MHz | -5.65 | -6.59 | -3.09 | 49.12 | 4.50 | -3.09 |
| 5000 MHz | -7.54 | -8.34 | -4.91 | 32.25 | 1.86 | -4.91 |
| 5150 MHz | -6.62 | -7.39 | -3.98 | 40.02 | 3.48 | -3.98 |
| 5350 MHz | -7.07 | -7.38 | -4.21 | 37.93 | 4.08 | -4.21 |
| 5650 MHz | -6.03 | -6.83 | -3.40 | 45.71 | 2.96 | -3.40 |
| 5750 MHz | -6.96 | -8.11 | -4.49 | 35.59 | 1.70 | -4.49 |
| 5850 MHz | -6.36 | -7.05 | -3.68 | 42.84 | 2.47 | -3.68 |
| 6000 MHz | -5.42 | -6.47 | -2.91 | 51.23 | 4.15 | -2.91 |
| 7125 MHz | -4.88 | -5.44 | -2.14 | 61.09 | 5.26 | -2.14 |

2400Mhz:

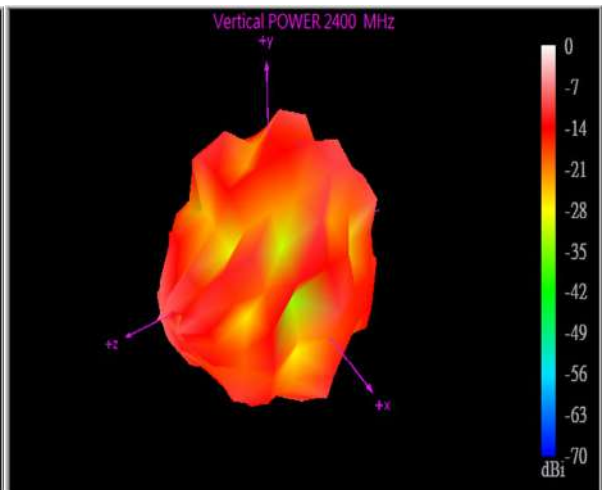
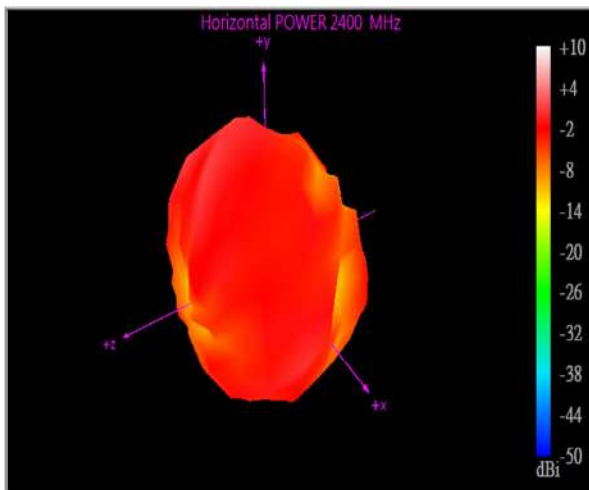
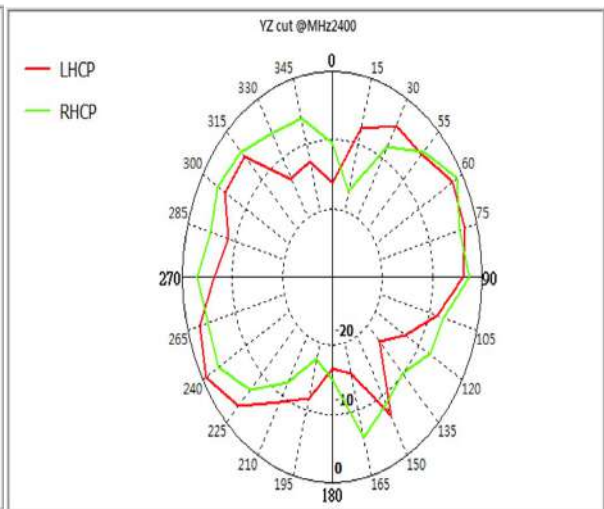
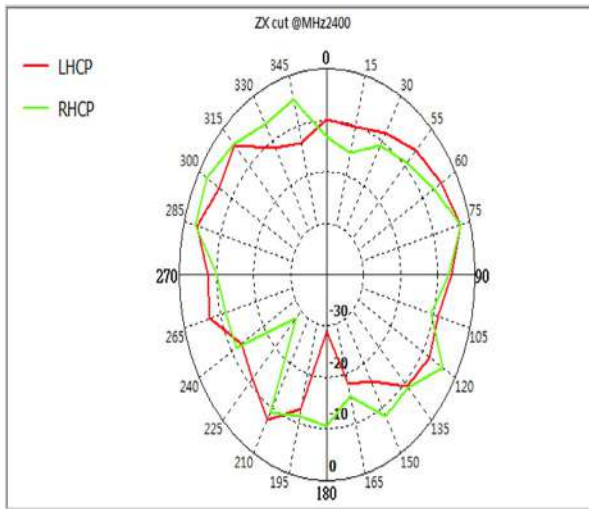
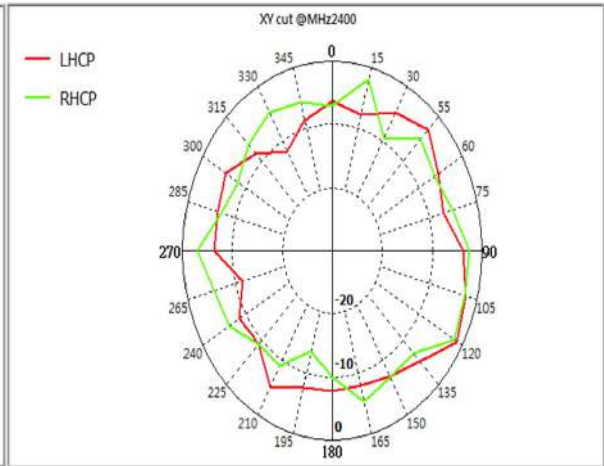
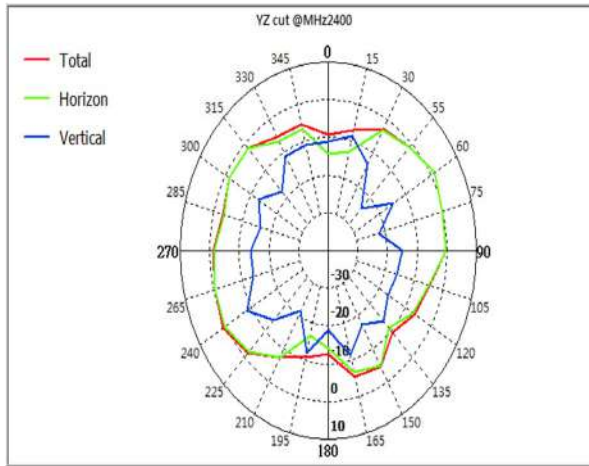
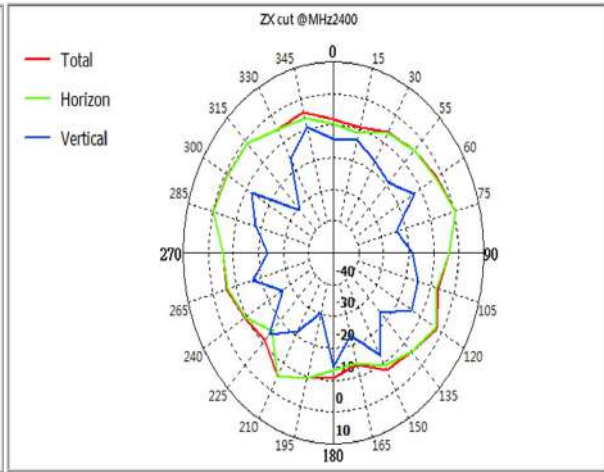
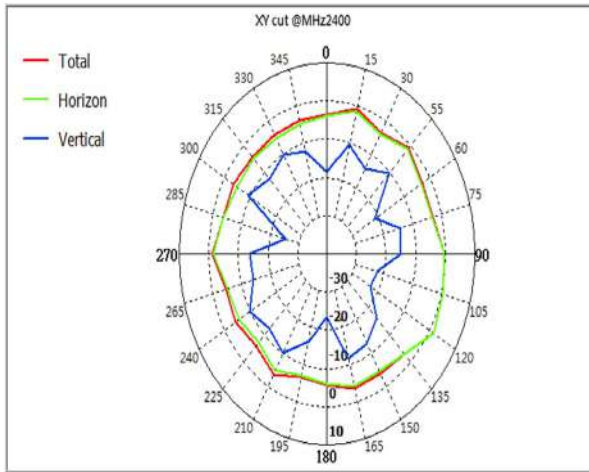

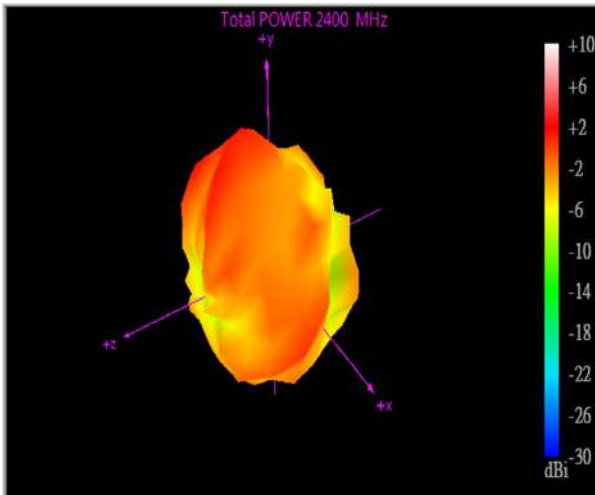
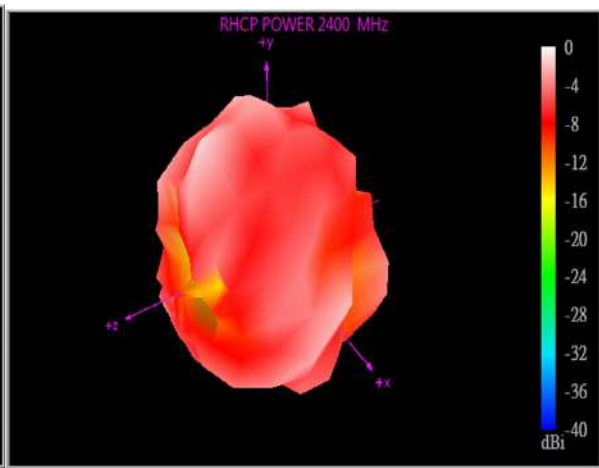
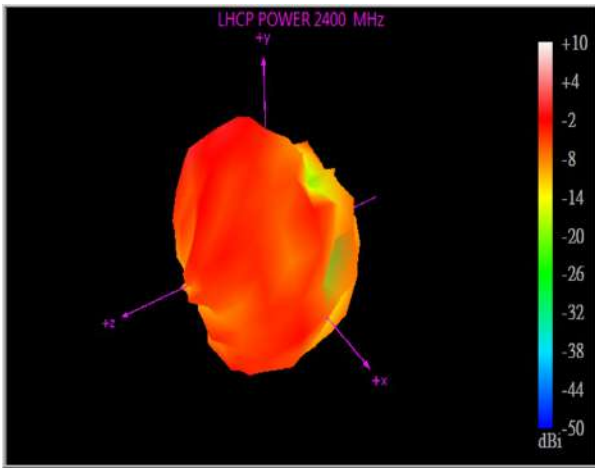

2450Mhz:

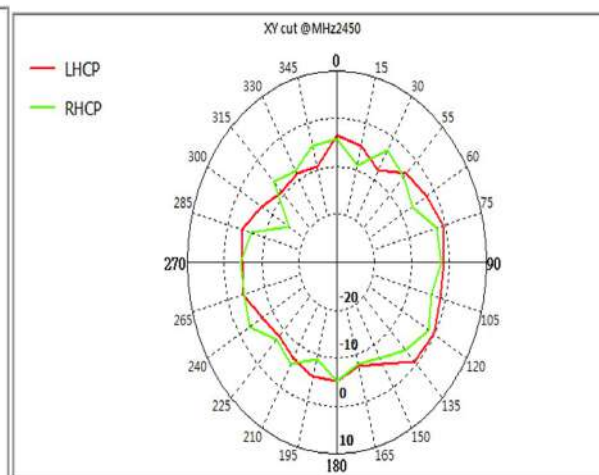
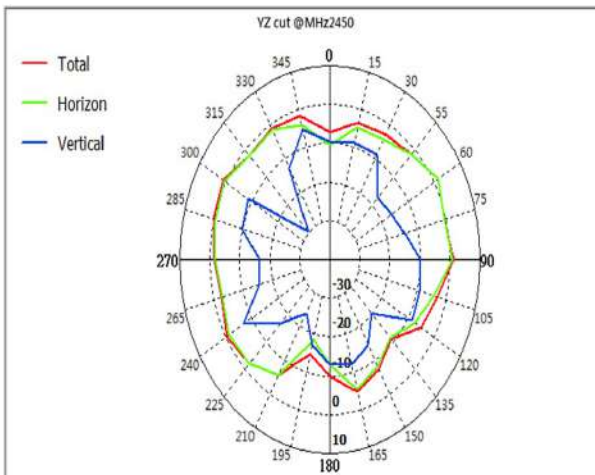
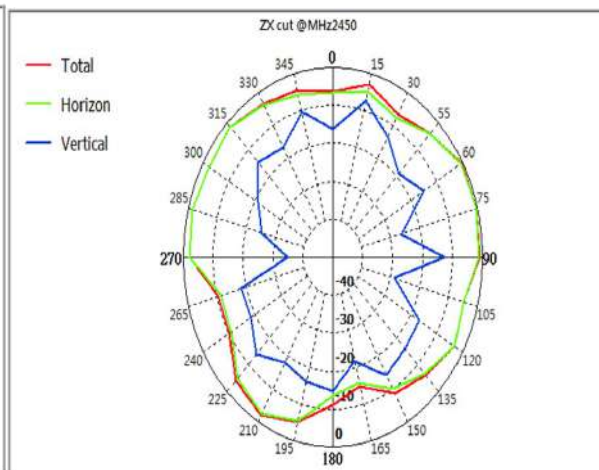
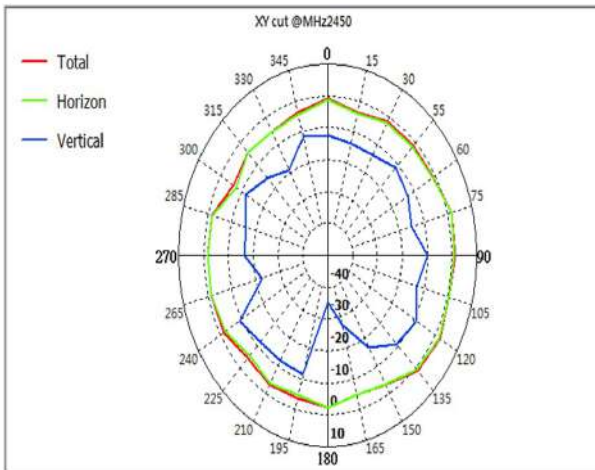

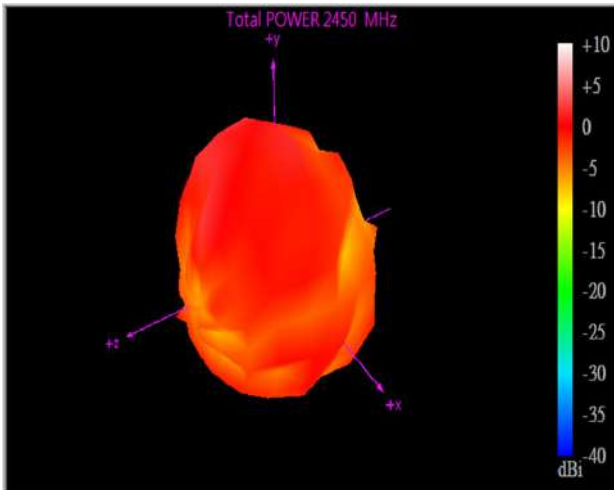
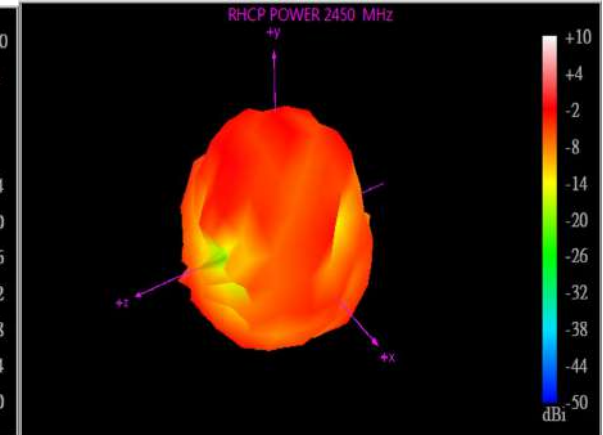
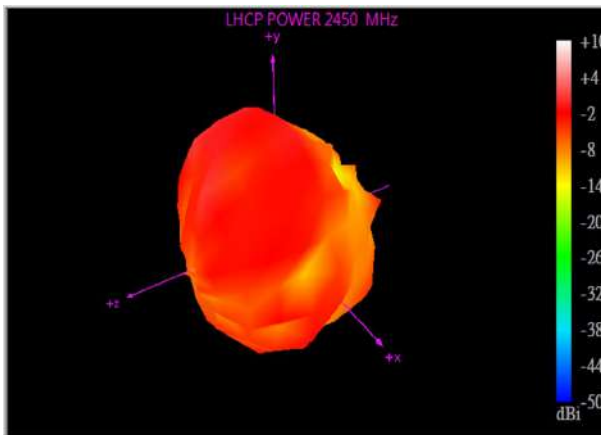
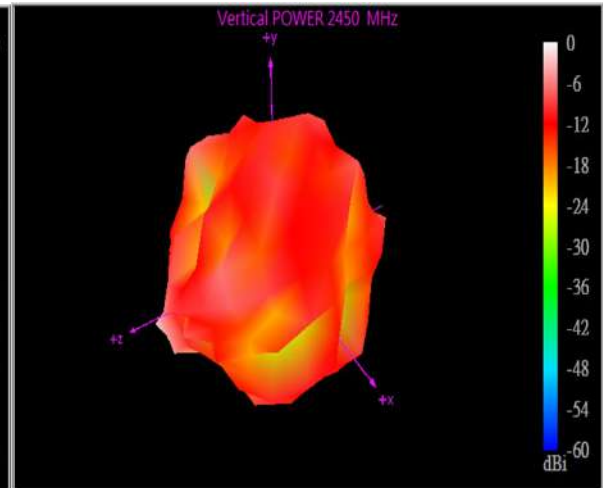
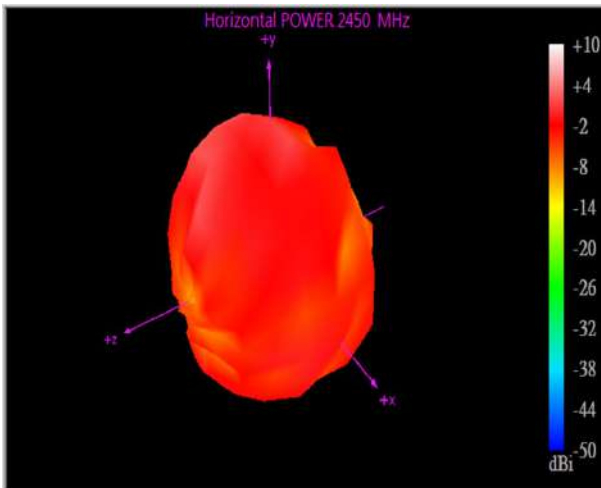
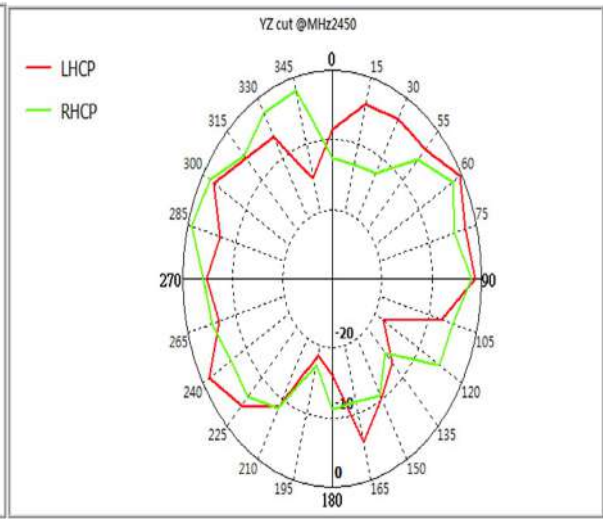
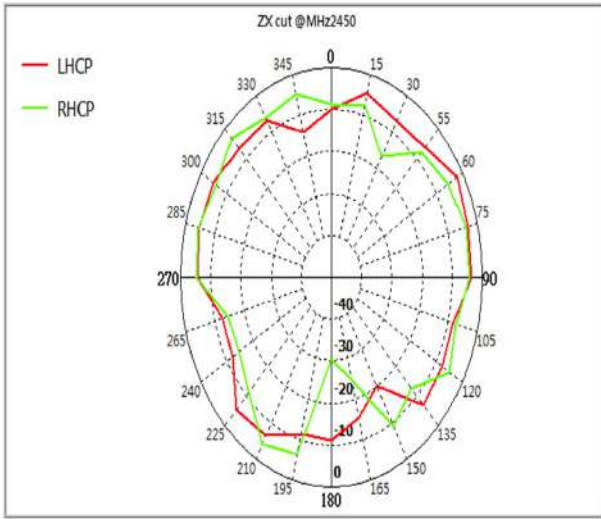

2500Mhz:

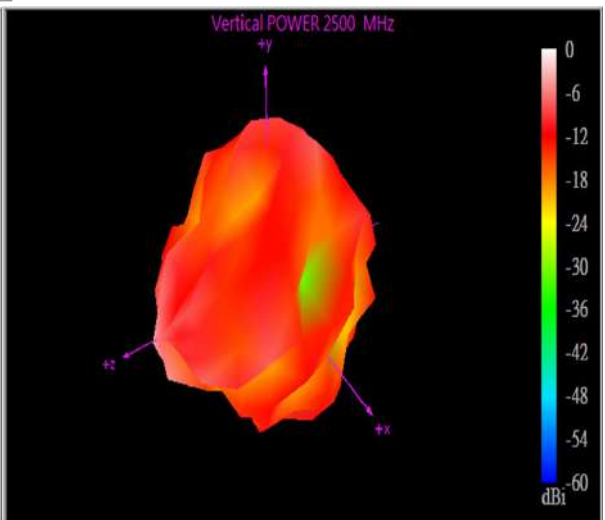
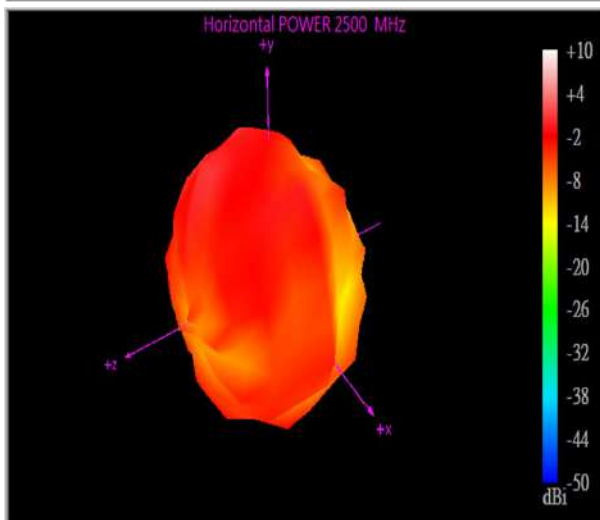
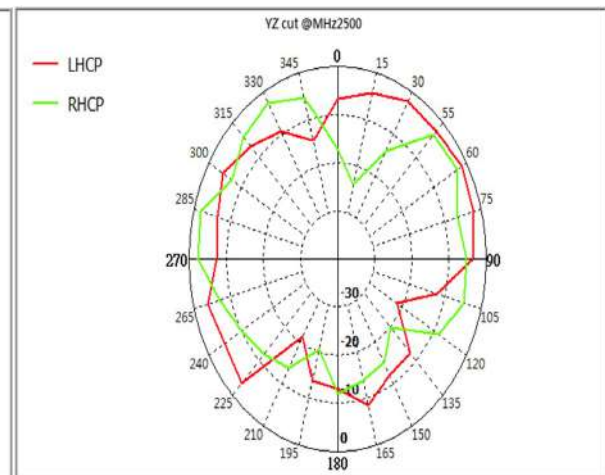
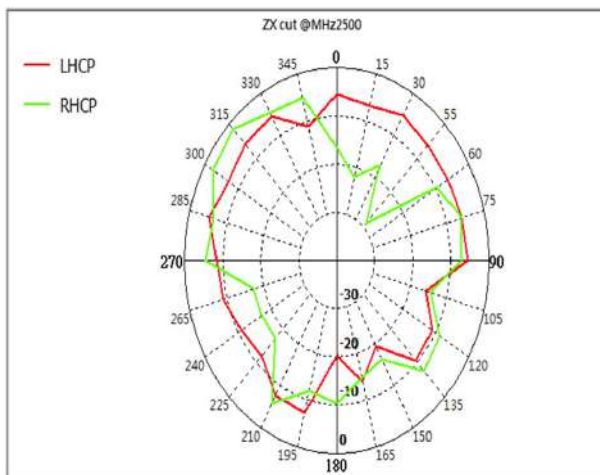
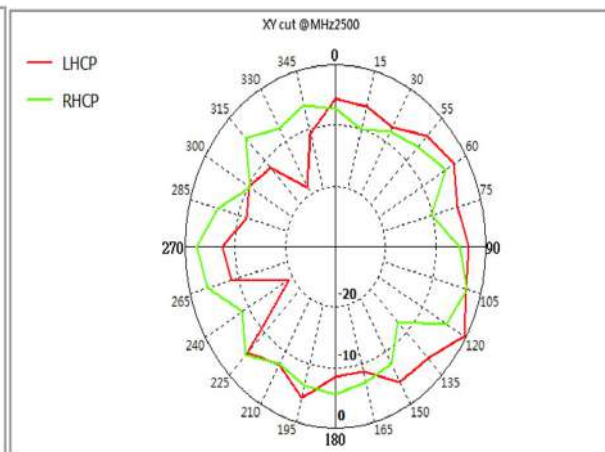
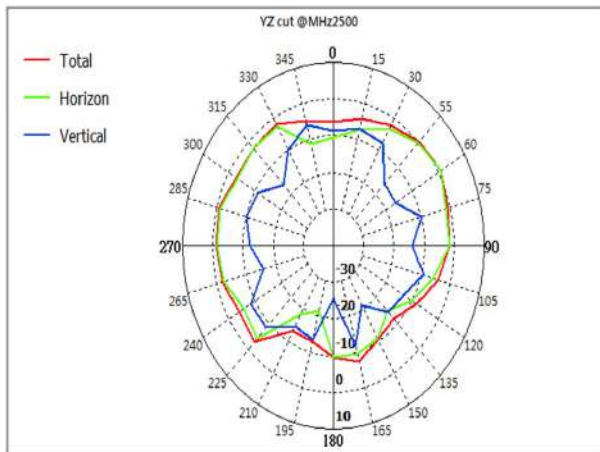
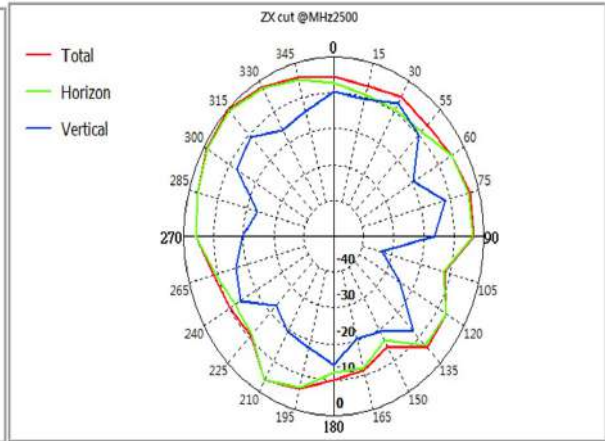
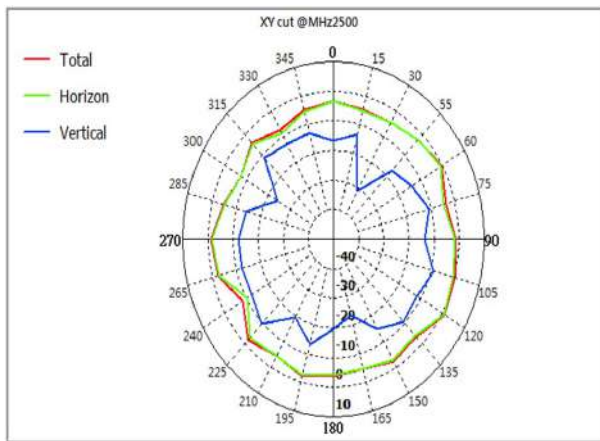

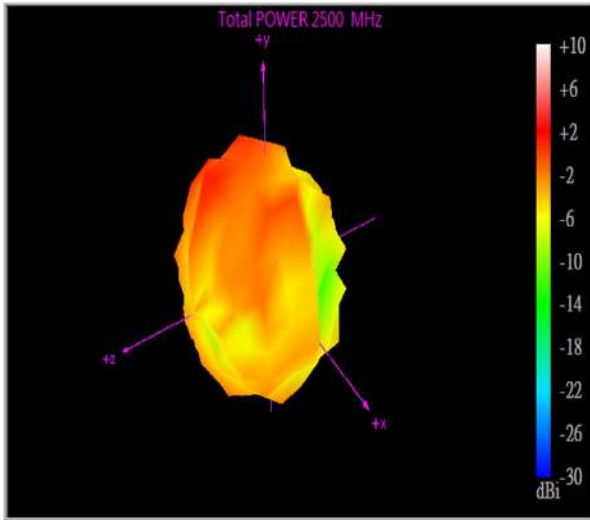
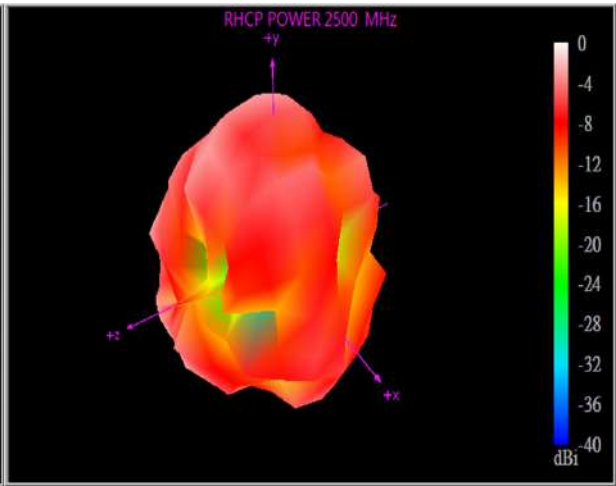
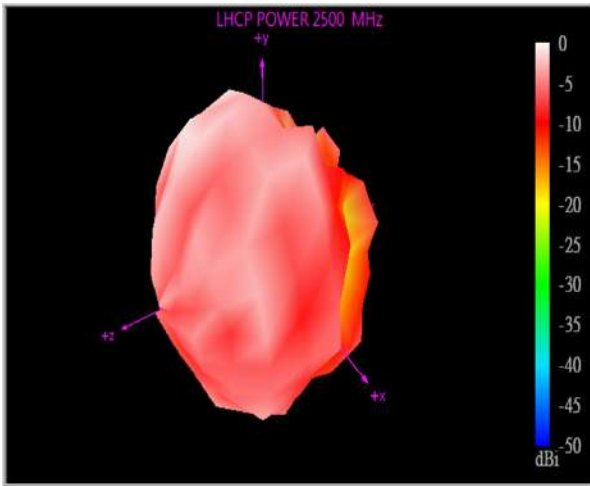

5150MHz:

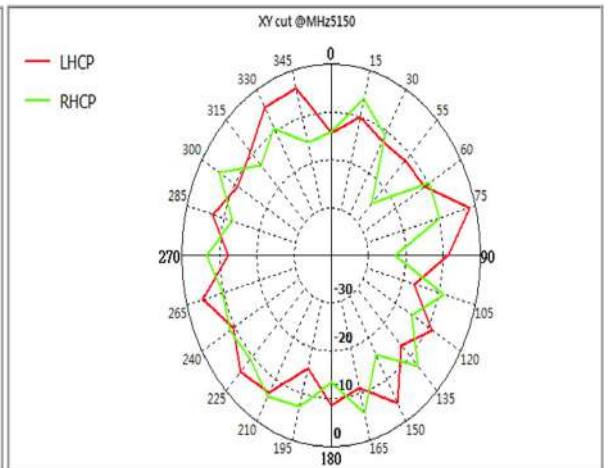
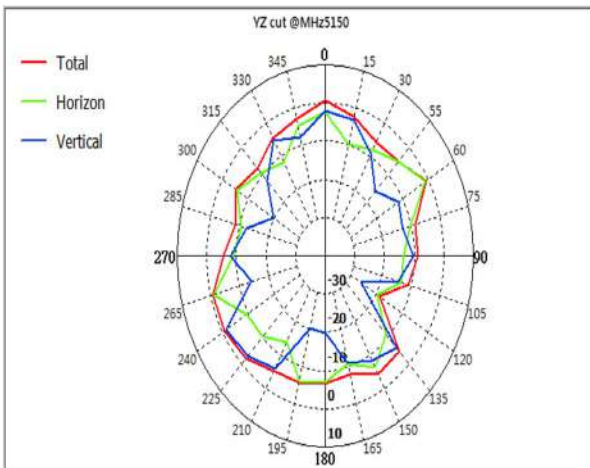
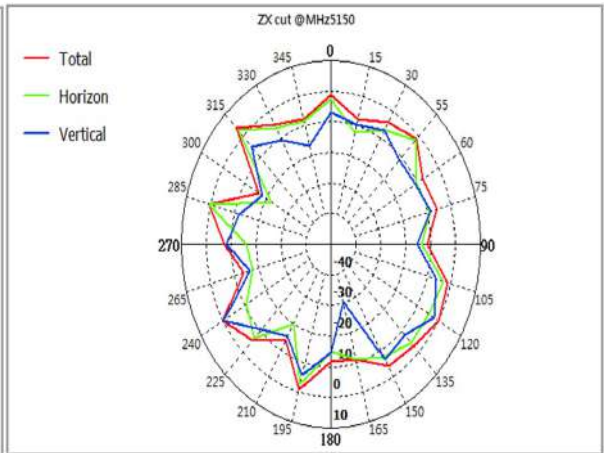
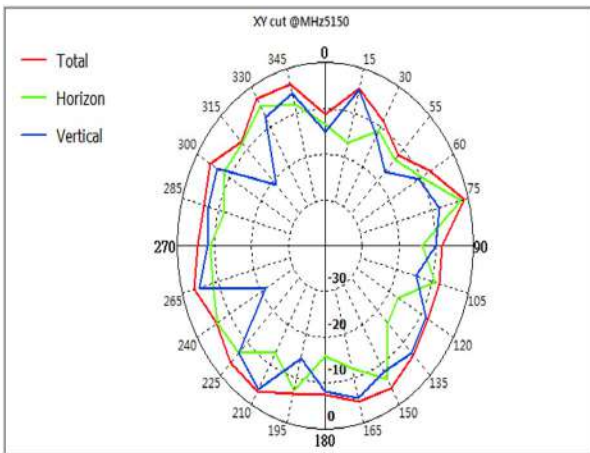

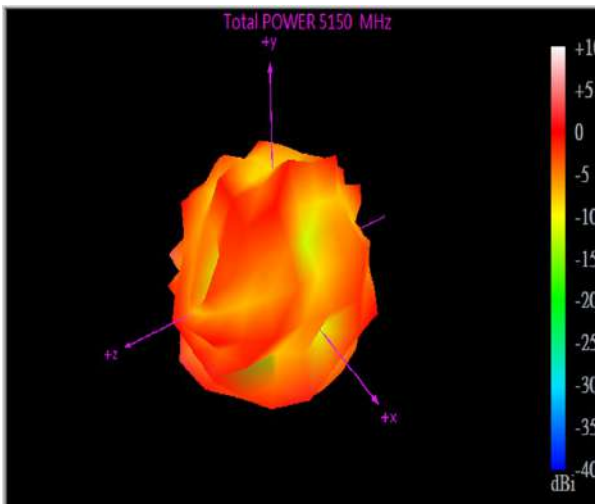
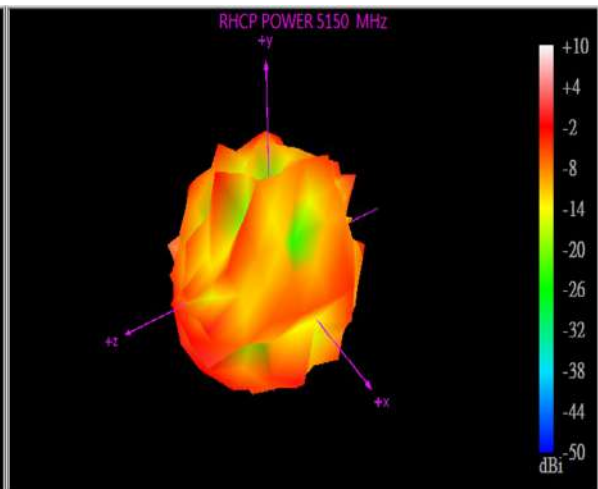
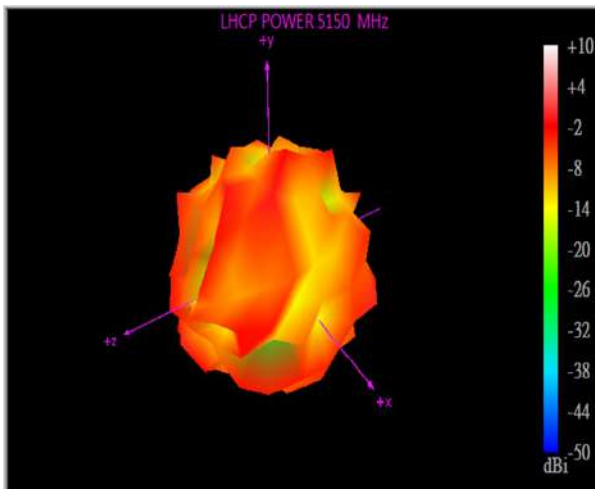
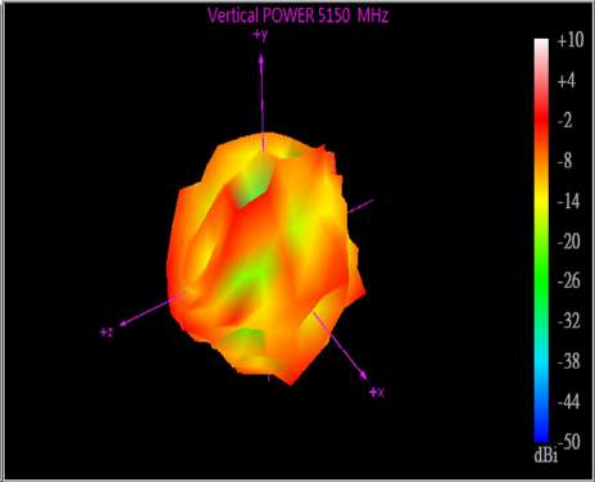
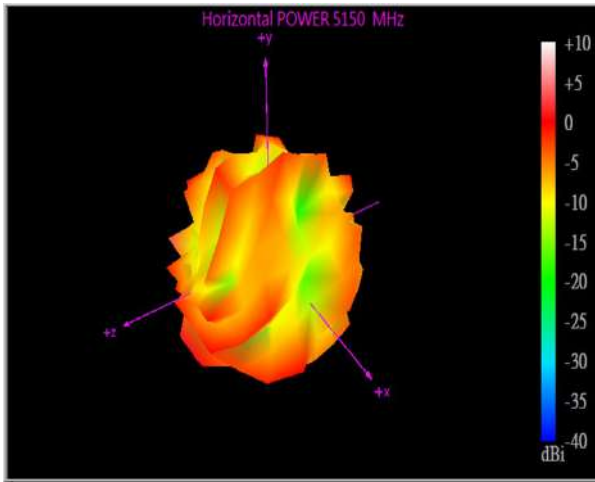
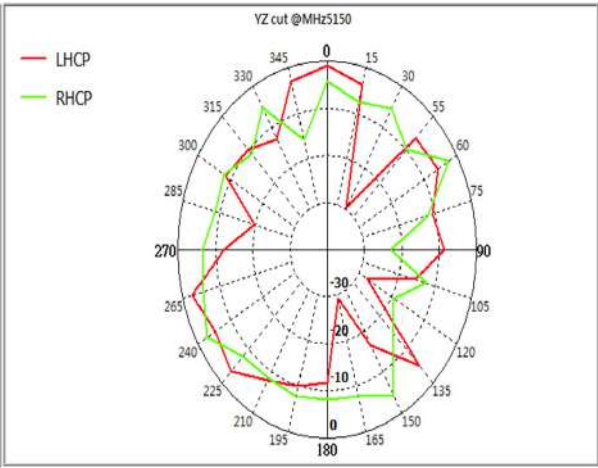
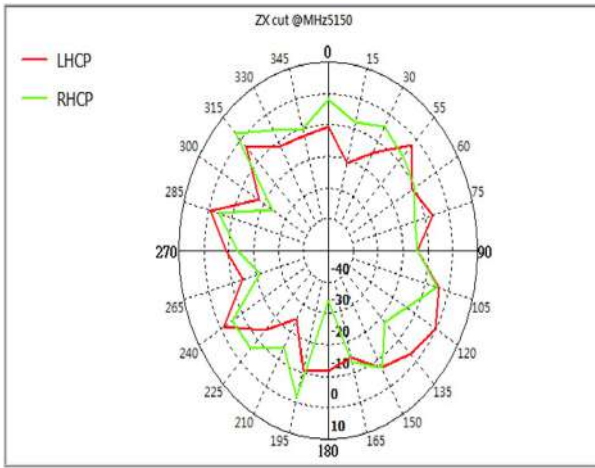

5350Mhz:

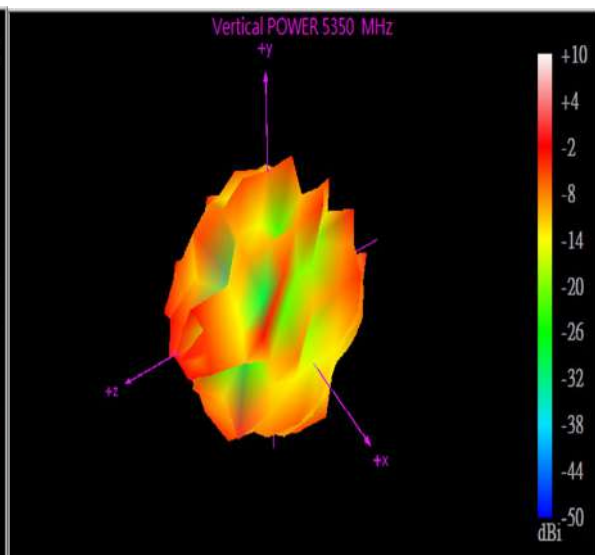
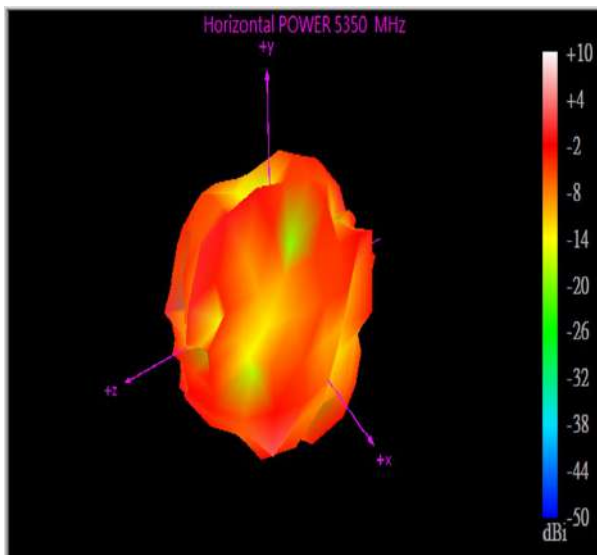
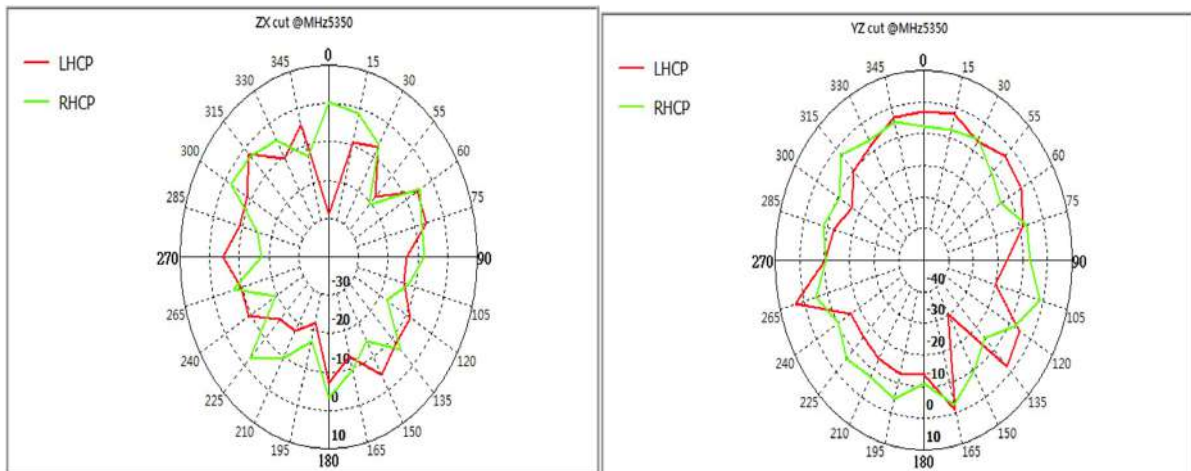
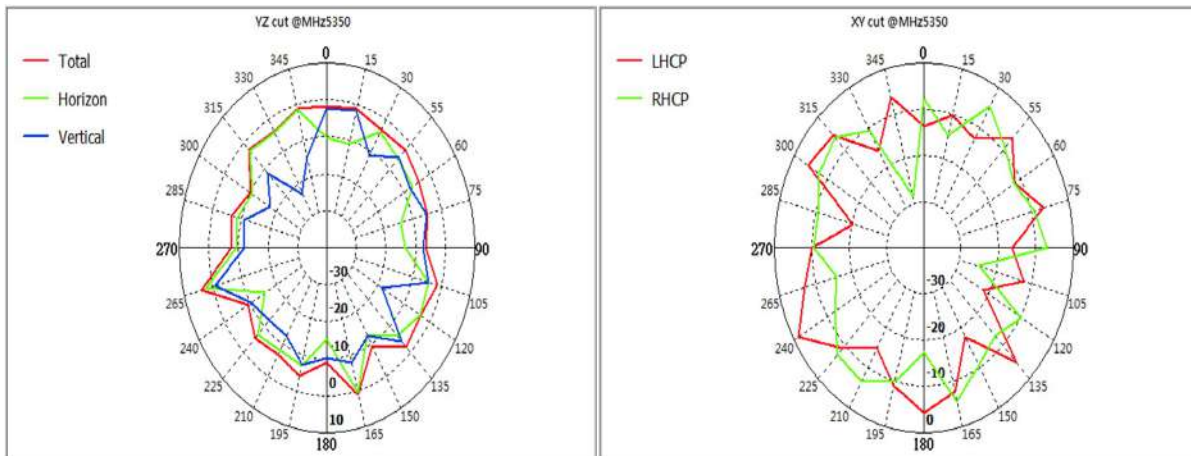
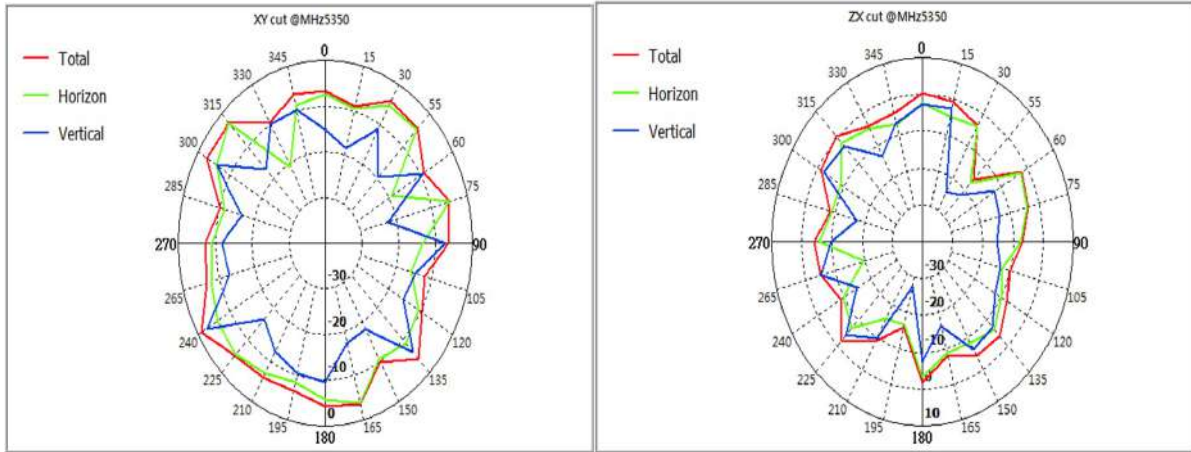

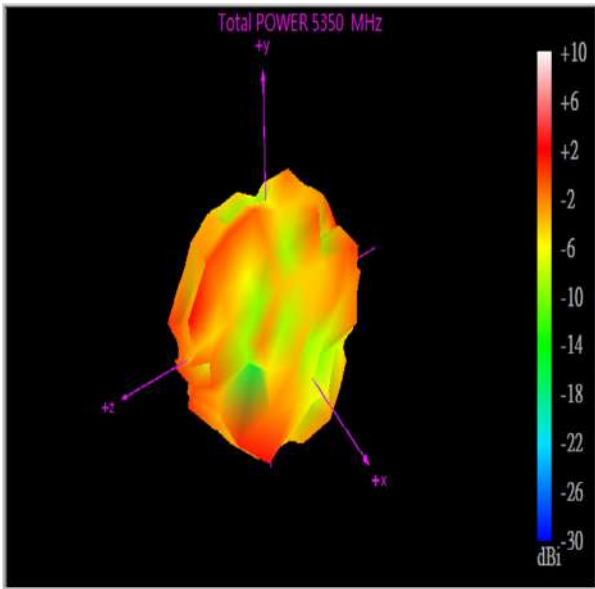
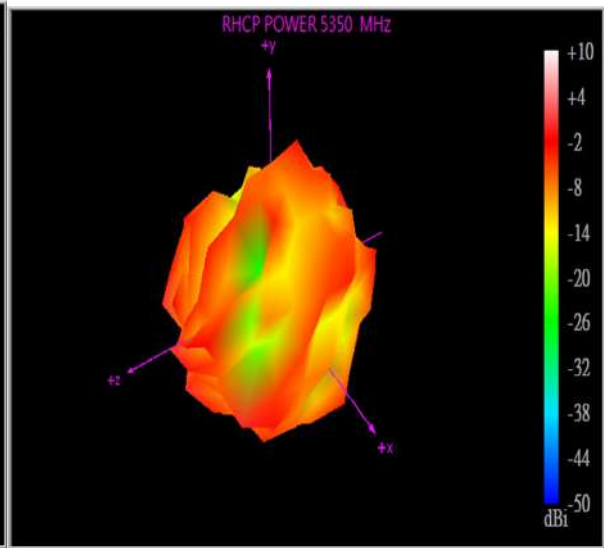
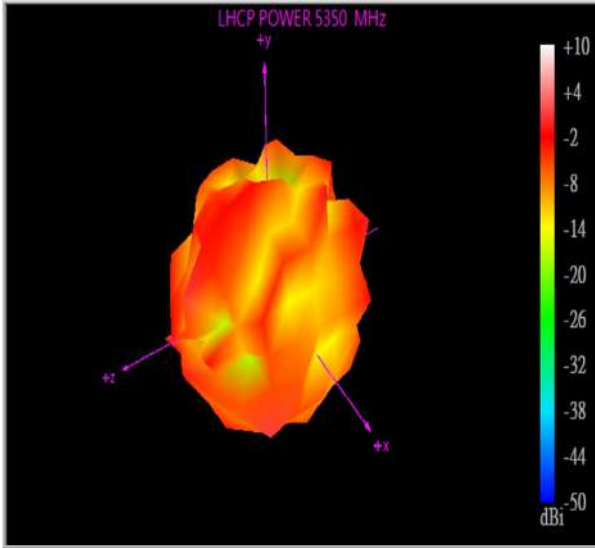

5650Mhz:

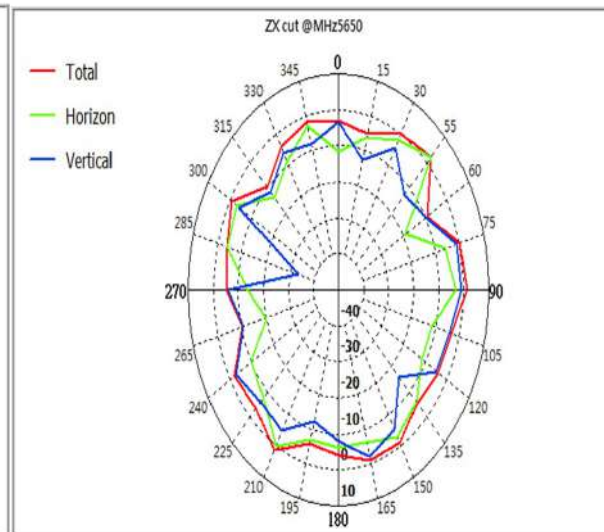
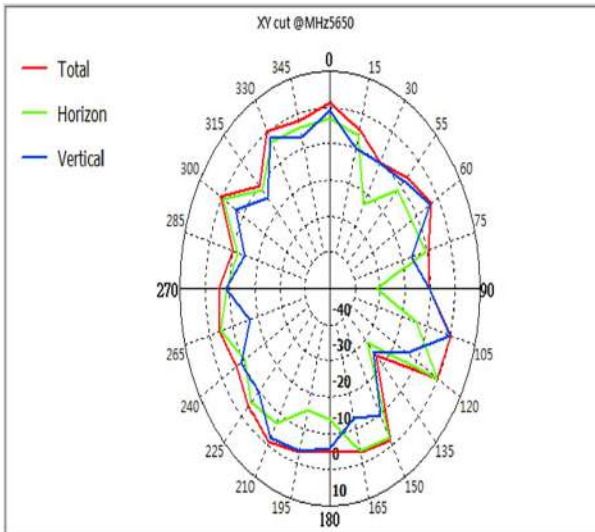

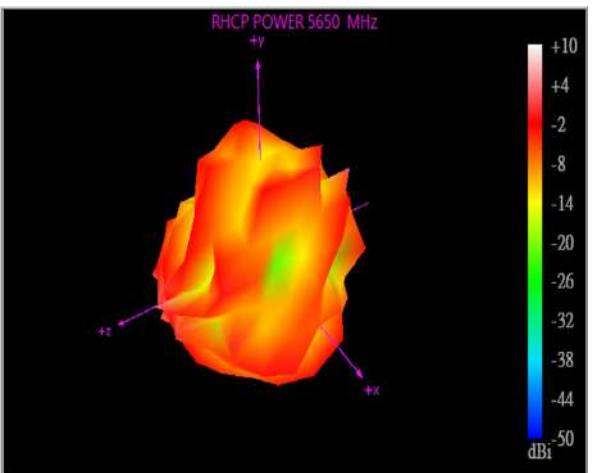
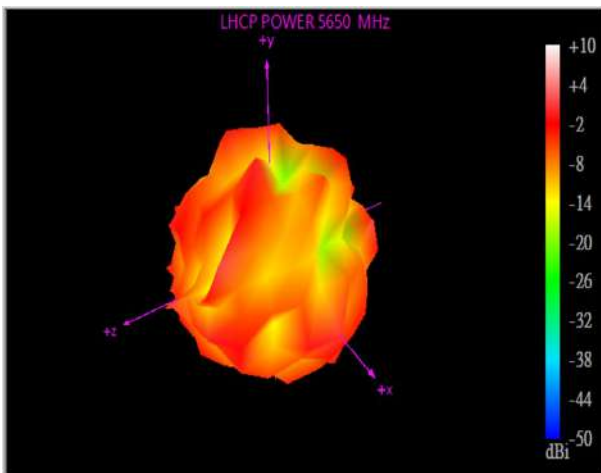
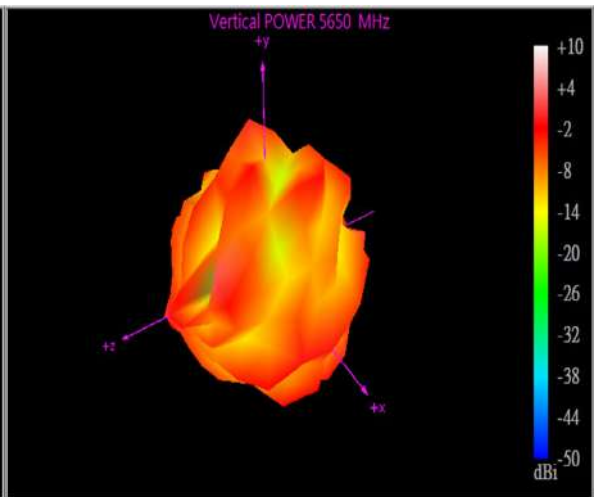
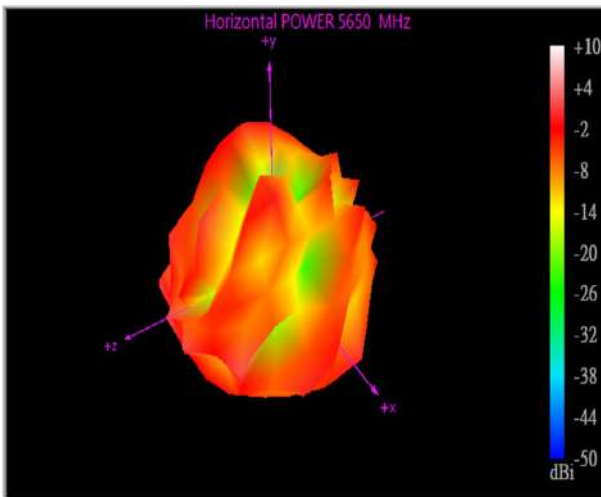
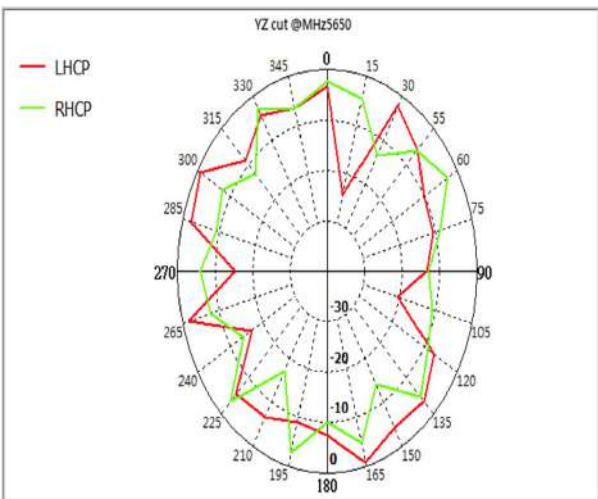
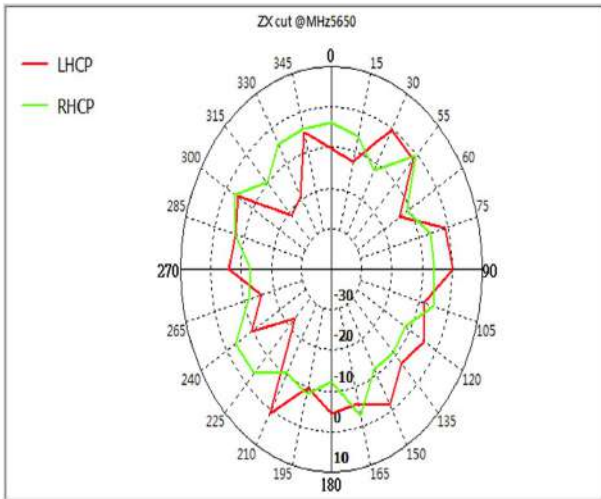
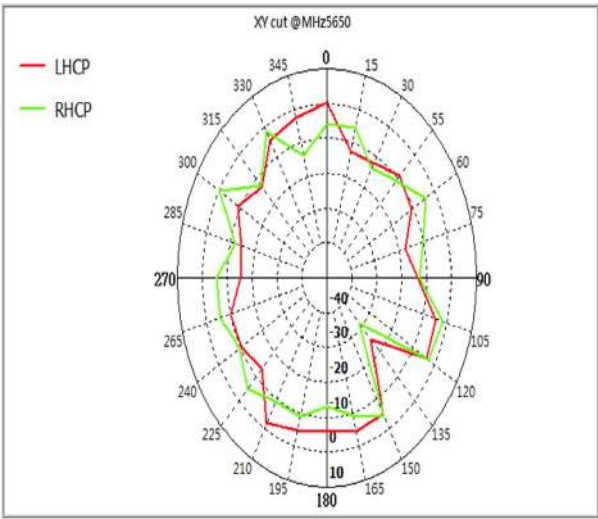
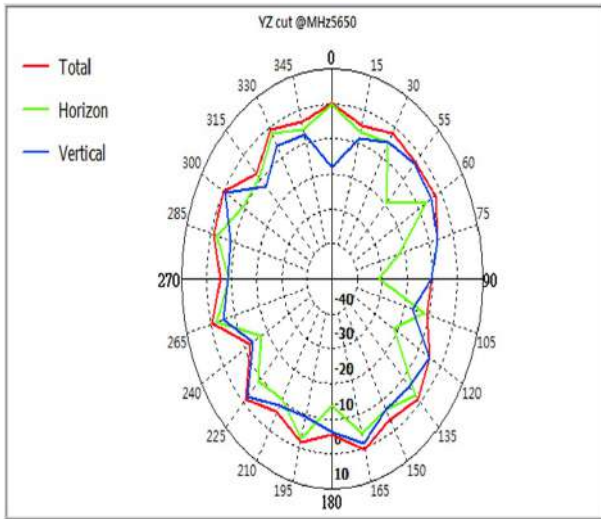

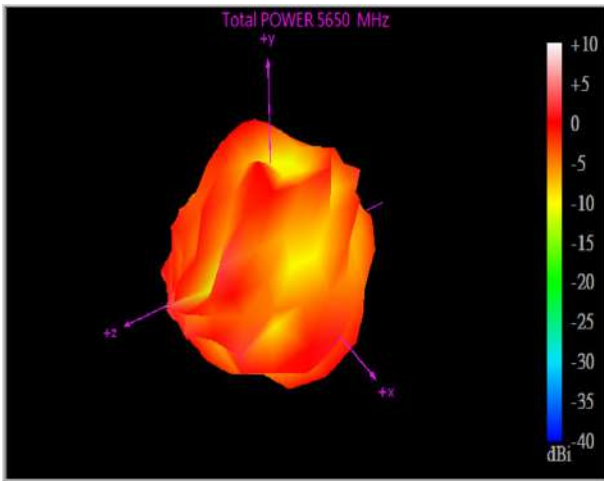

5850MHz:

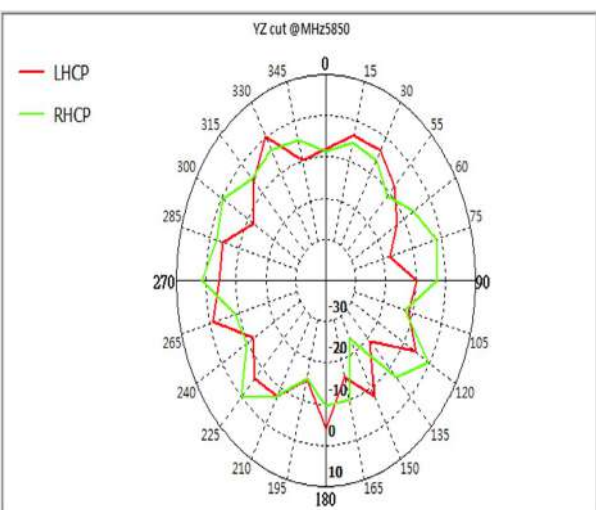
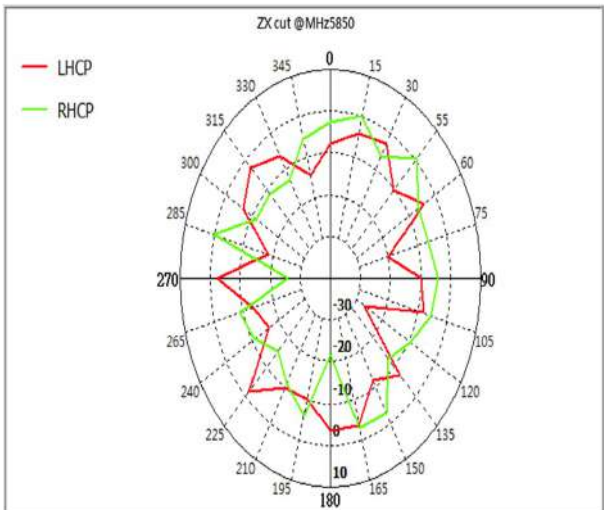
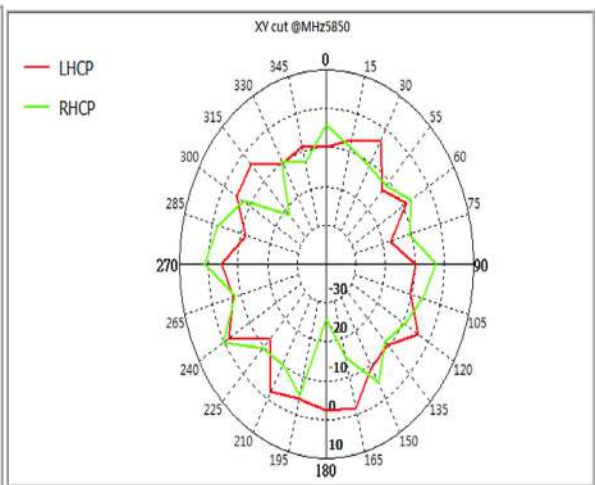
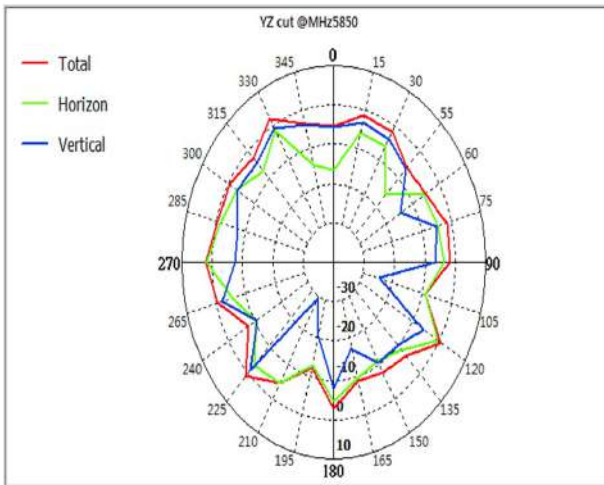
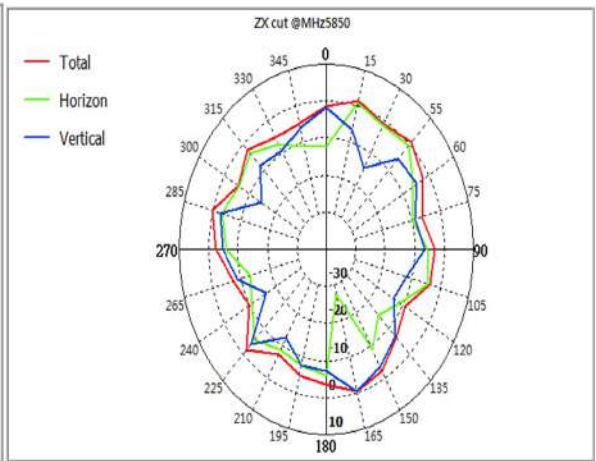
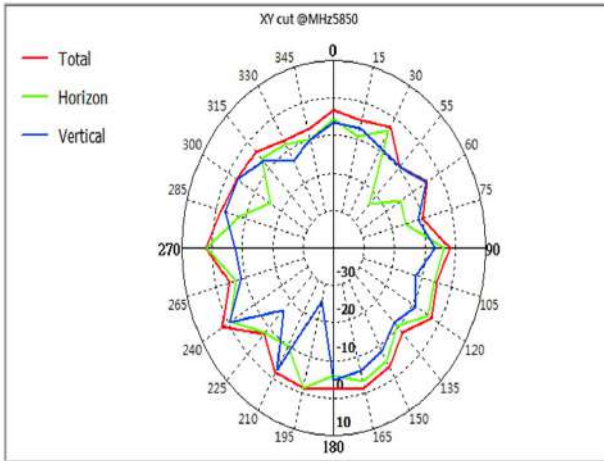

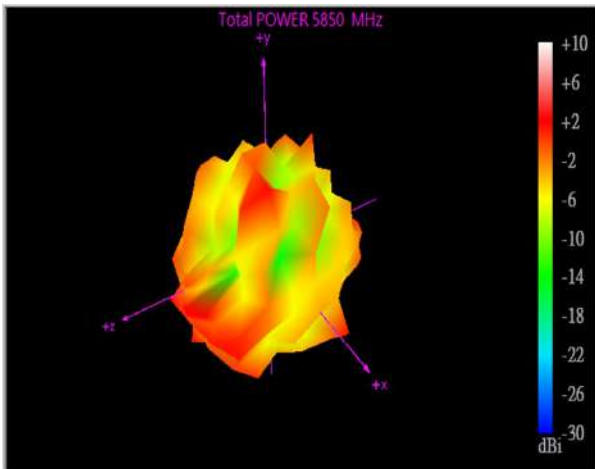
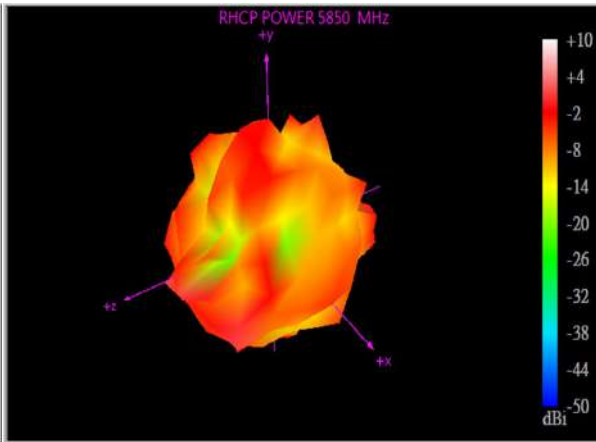
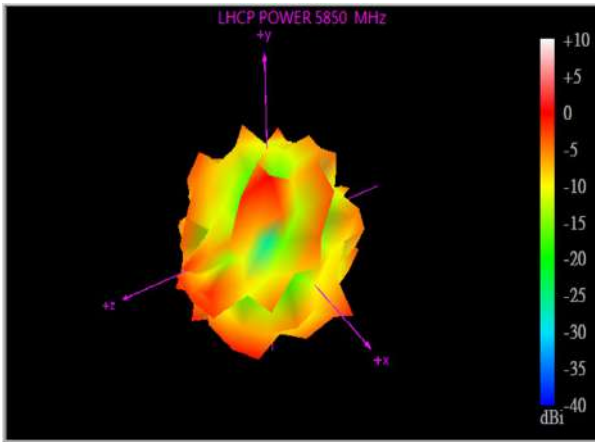
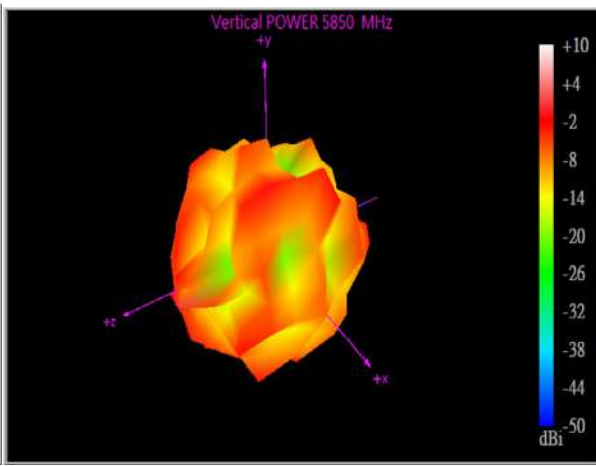
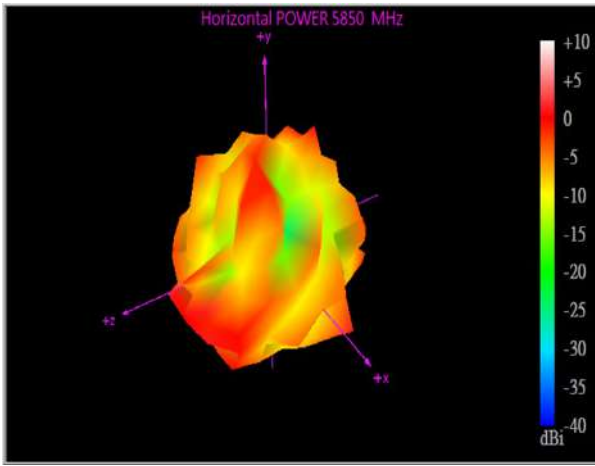

7125Mhz:

